

Resson

Technologies

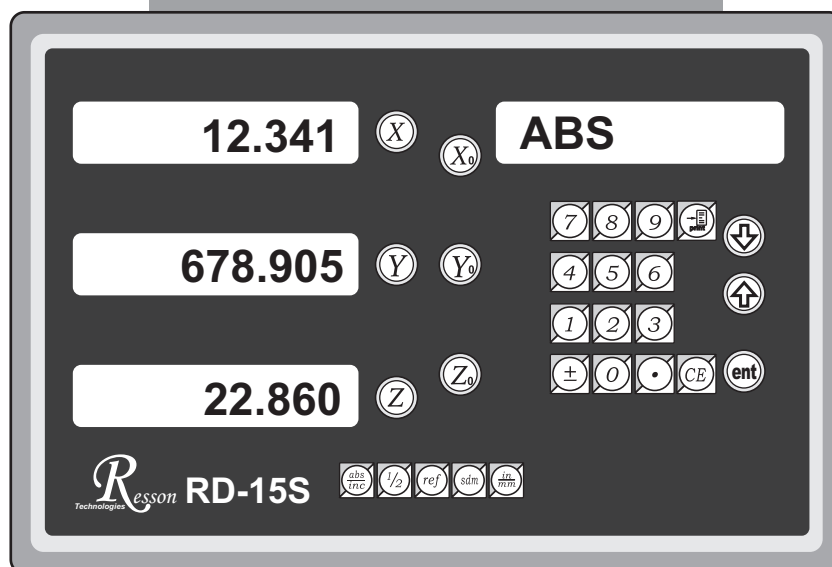

RD-15S

Digital Readout System
Operation Manual
(Standard)

Resson Technologies Co., Ltd.

Note before using this display !

● Use the defined voltage

The rated power voltage supplied to this display should be 100V~230V, select correct voltage supply and try best supplying the power from lighting power line!

Since the power circuit would become unstable under frequent power on/off and cause instant strong interference or even power shutdown; take special note on it!

● Ground the display!

To guaranty user safety and stable & reliable system work, we strongly request user connecting the attached ground line (3-m yellow-green cable packed in the packaged box to the FC terminal at back of display to make good grounding connection!

● Insert each axis optic rule into correct position before turning on display; if doing the turn inversely, it might burn out the electronic devices in the optic ruler!

● Do not operate this display in elevated ambient temperature or under high humidity!

● Do not operate this display in strong electric field, magnetic field or noisy environment, or by electric machine that would be the main reason making system act in error!

● Use dry, soft cloth to wipe cleaning display surface!

● For stain hard to remove, use soft cloth wet by neutral detergent to clean it up!

● Do not use gasoline, diesel fuel, kerosene or alcohol to wipe cleaning the display surface!

● Do not use compressing air gun to blow display and optic scale assembly since it would blow oil, moisture, dust or chips into them from seam and cause system unstable and damage!

Elaborate maintenance, correct operation;

Extend operation lifetime and stabilize work performed

**Thanks for buying our product! To use it correctly,
read this Operation Manual carefully and in details.**

RD-15S Specification :

Number of axes : 1、2、3

Resolution : 0.05/0.02/0.01/0.005/0.002/0.001/0.0005/0.0002/0.0001mm

Display function : 8-digit LED

Response speed : 60m (198.6feet)/min

Quantizing error : ± 1 count

Power source : AC100V~230V / 50~60Hz / 20VA

Temperature fange : Service:0~40°C / Storage:-20~70°C

Linear Encoter (Scales) Electrical connector :

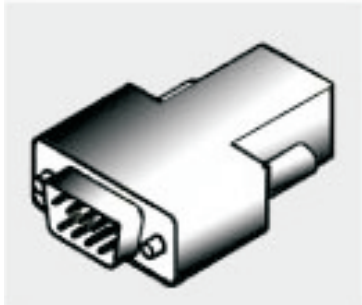

D-sub 9 pins connector



TTL

PIN	SIGNALS
1	N/C
2	0V
3	N/C
4	Inner shield
5	N/C
6	A
7	5V
8	B
9	R

N/C : No Connection

RS422

PIN	SIGNALS
1	A-
2	0V
3	B-
4	Inner shield
5	R-
6	A+
7	5V
8	B+
9	R+



DIN 7 pins connector



PIN	SIGNALS
1	0V
2	N/C
3	A
4	B
5	5V
6	R
7	Inner shield

N/C : No Connection

RS232 output port

This display has RS232-C output port facilitating user to print out the measuring result or connect it to a computer; the port's picture is as below.

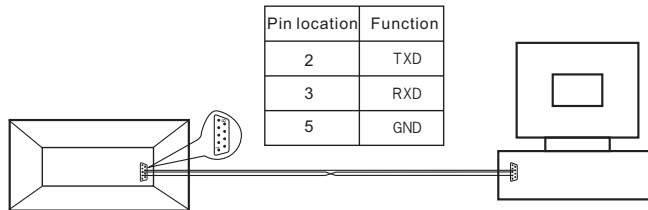



The display's RS232 output port transmission parameters are:

BAUD RATE : 57600/19200/9600/4800/2400/1200bps
 DATA : 8 data bits
 STOP BITS : 1 stop bit

Through the display's RS232 output port, we can output display data to a computer or send the output or reset command to display from the computer; such as asking axis X to reset CX, axis Y to reset CY and axis Z to reset CZ.

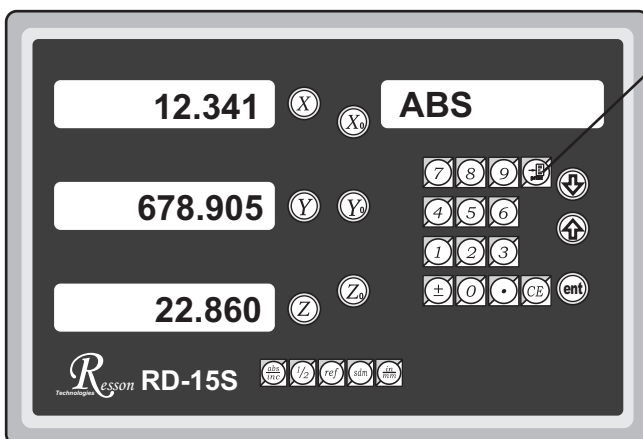
RS232 output function



Press  to output display data; and set the "print" option to "on"; to apply two-way communication, set the "print" option to off.

User may select EPSON LQ-300+RS232 as the working printer; set speed to 19200bps and turn on the print to standby.

The back shell plug seat of DRO.

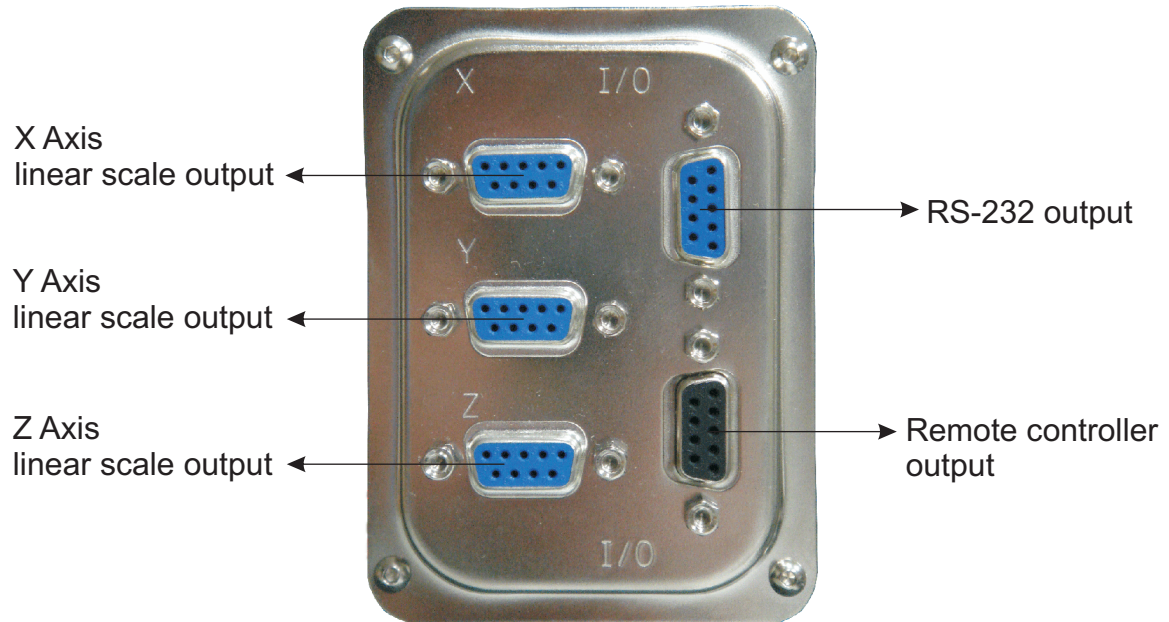

一. Basic Functions	1
二. REF datum memory	5
三. 199 SubDatum Function	11
四. Parameters Setup Function	20

Basic Functions

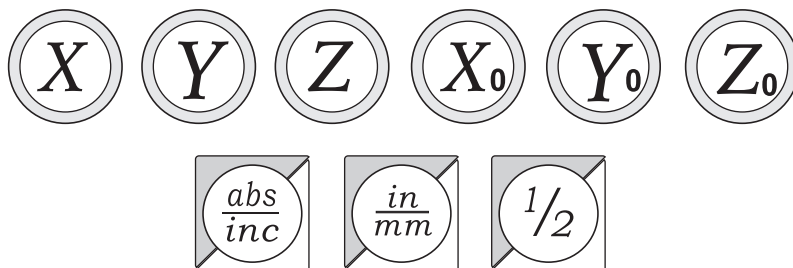
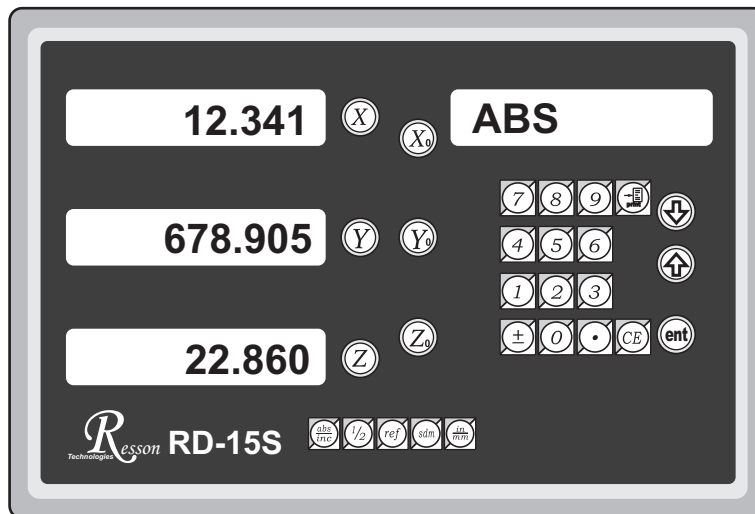

Set Display to Zero

Purpose : Set the current position for that axis to zero

Example : To set the current **X Axis** position to zero

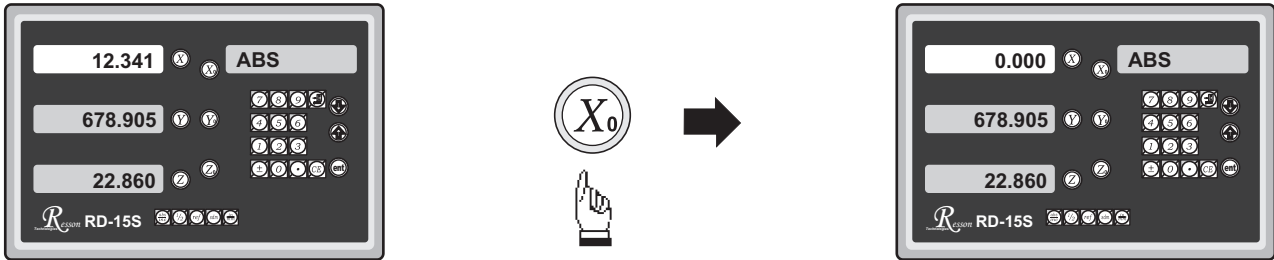

Inch / Metric Display Conversion

Purpose : Switches between inch and metric display

Example 1 : Currently in **inch** display, to switch to **metric** display

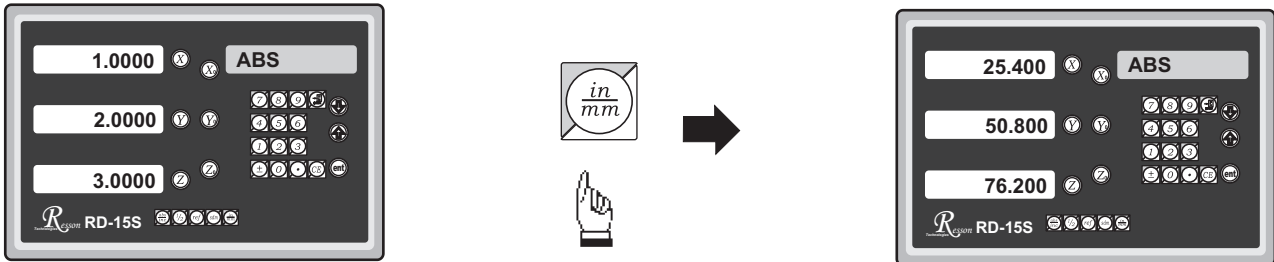

Example 2 : Currently in **metric** display, to switch to **inch** display

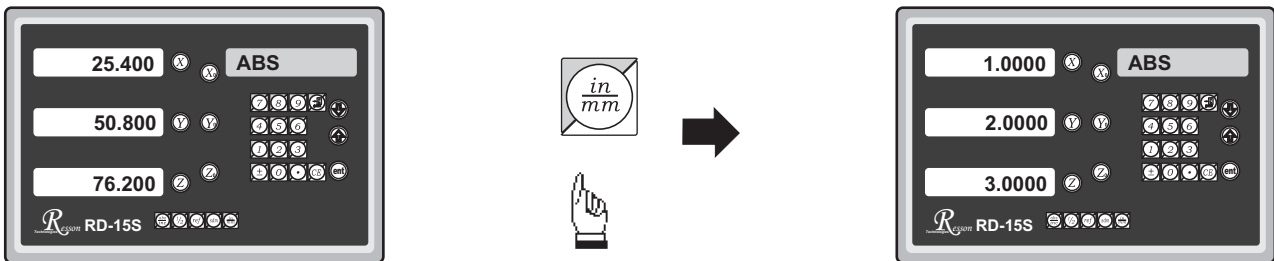

Enter Dimensions

Purpose : Set the current position for that axis to an entered Dimension

Example : To set the current **X Axis** position to **45.800 mm**

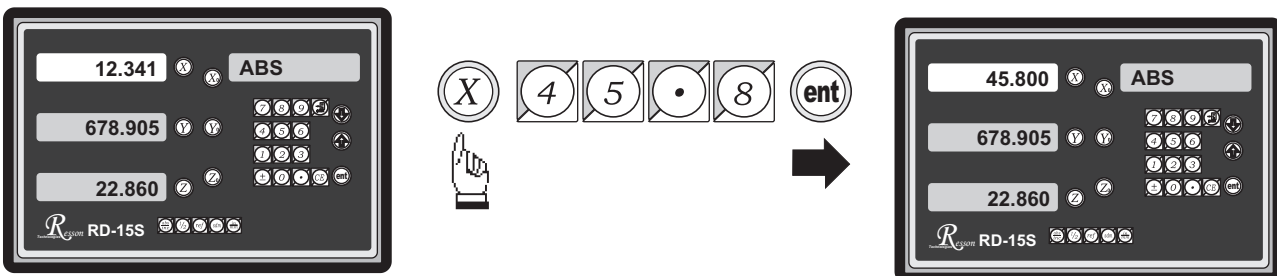

ABS / INC Coordinates display switches

Purpose : RD-15S provides two sets of basic coordinate display, they are **ABS** (absolute) and **INC** (incremental) displays.

During machining operations, the operator can *store the work piece datum (zero position) in **ABS** coordinate, then switch to **INC** coordinate to continue machining operations.*

The operator is then free to zero the axes or preset any dimensions into any axis in **INC** coordinate for relative position machining. The work piece datum (work piece zero position) is still retained in **ABS** coordinate by the **RD-15S**.

Operator can then toggle between **ABS** (absolute) and **INC** (incremental) coordinates without losing the work piece datum (work piece zero position).

Example 1 : Currently in **ABS** display coordinate, to switch to **INC** display coordinate

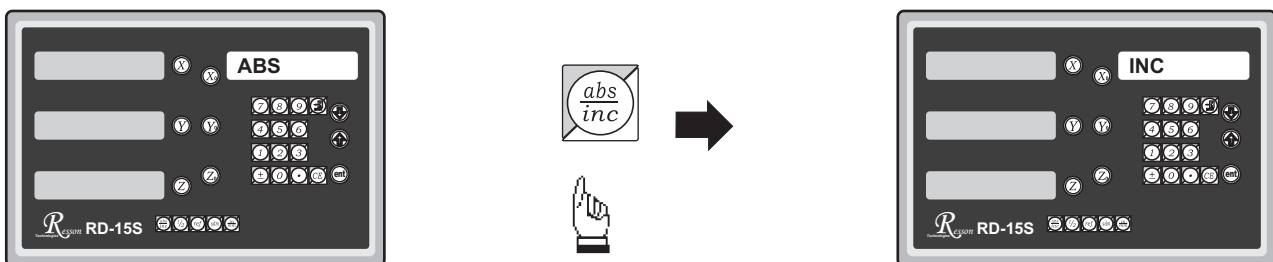

Example 2 : Currently in **INC** display coordinate, to switch to **ABS** display coordinate

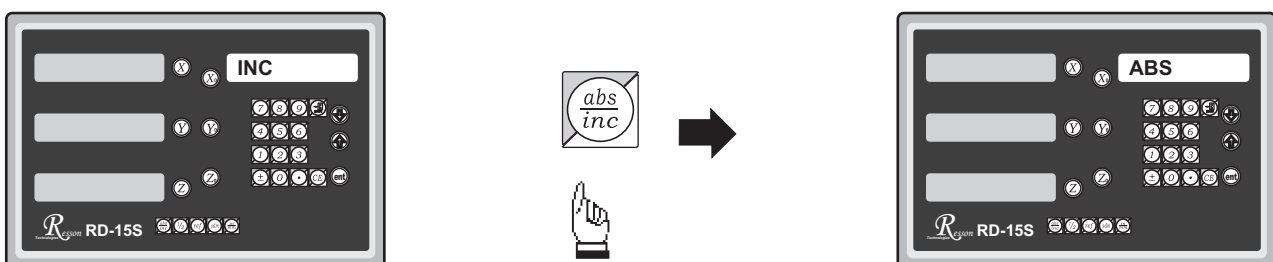

Purpose : RD-15S provides the centre-find function by halving the current display coordinate, so that the zero point of the work piece is located at the centre of the work piece.

Example : To set the X Axis zero point at the centre of the work piece.

Step 1 : Locate the edge finder at one end of the work piece, then zero the X Axis.

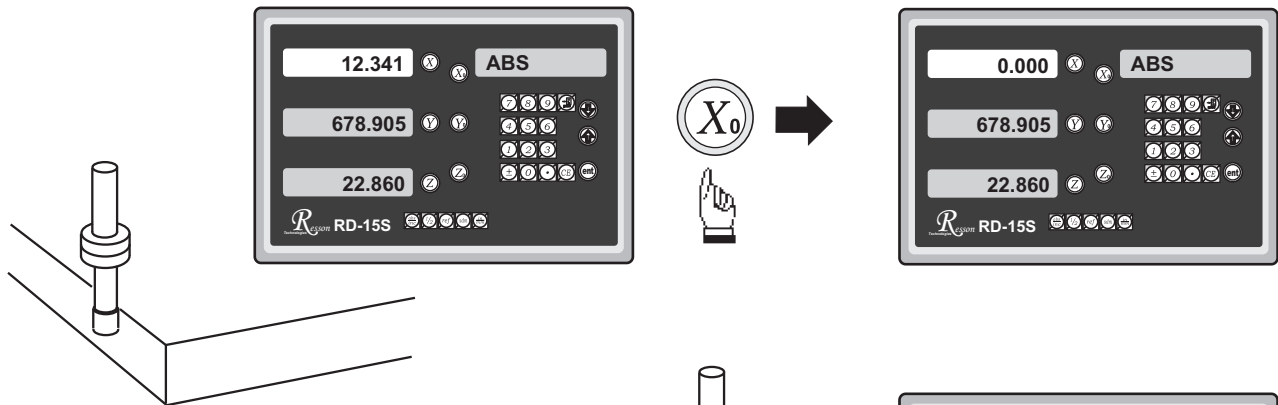

Step 2 : Locate the edge finder at the opposite end of the work piece.

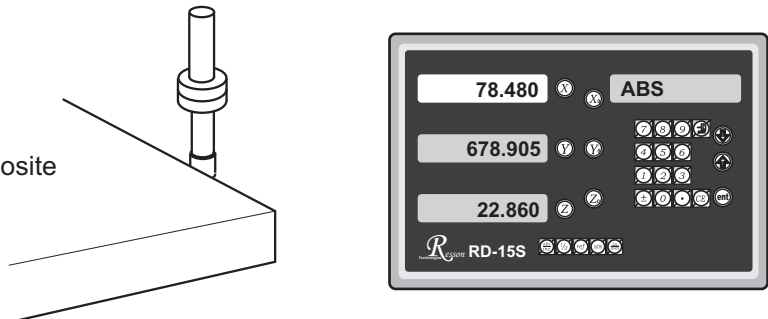

Step 3 : Then half the display coordinate using centre-find function as per follows:

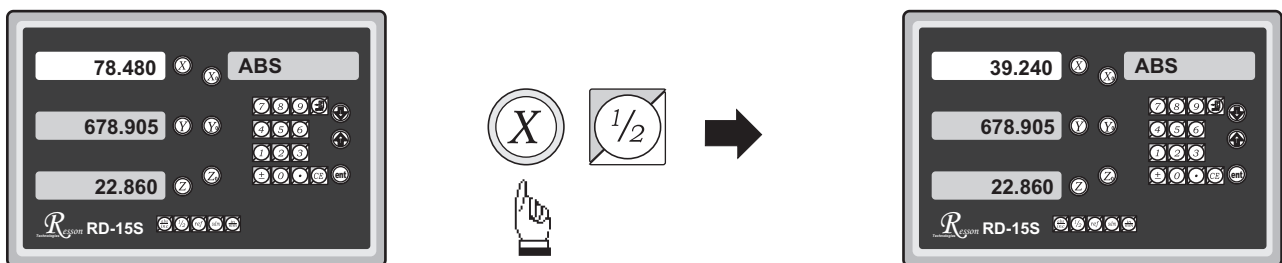

Now the X Axis zero point (0.000) is located at the X centre of the work piece.

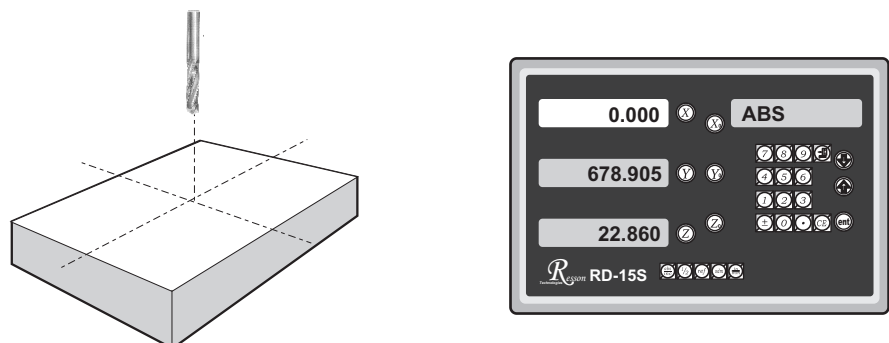

ref datum memory

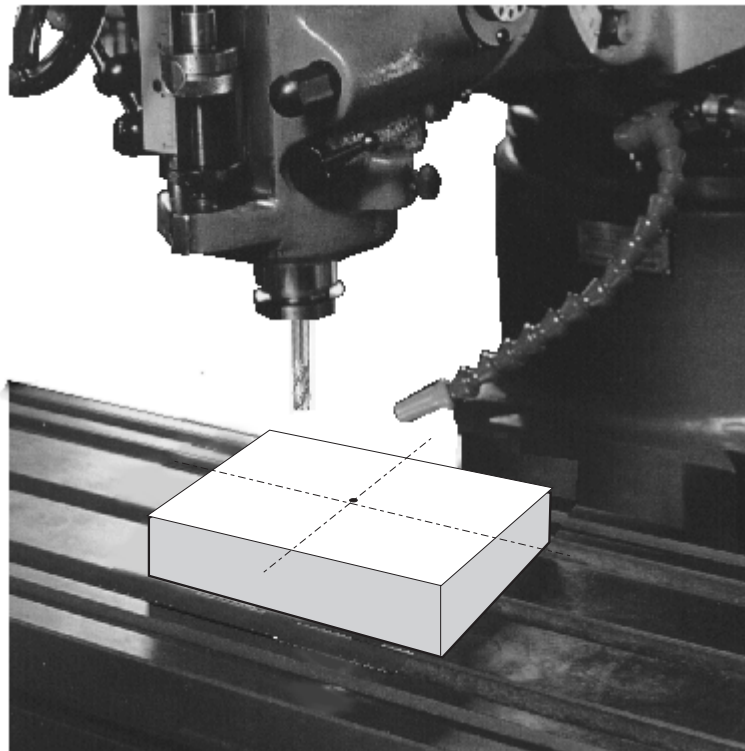
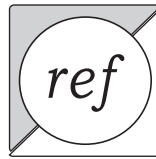

function : During the daily machining process, it is very common that the machining cannot be completed within one working shift, and hence the DRO has to be switched off, or less commonly, a power failure occurs whilst machining which leads to loss of the work piece datum (work piece zero position). The re-establishment of work piece datum using edge finder or other method inevitably introduces machining inaccuracies, because it is not possible to re-establish the work piece datum exactly at the previous position.

To allow the recovery of work piece datum very accurately, with no need to re-establish the work piece datum using an edge finder or other methods, every transducer has a reference point location to provide a datum point memory function.

The working principal of the ref datum memory function is as follows.

- There are a permanent and fixed mark (position) on the transducer, normally called **ref** mark or **ref** point..

Since this **ref** point position is permanent and fixed, it will never change or disappear when the DRO system is switched off. Therefore, we simply need to store the distance between the **ref** point and the work piece datum (zero position) in DRO's memory. Then, in case of the power failure or the RD-15S being switched off, we can recover the work piece datum (zero position) by presetting the display zero position as the stored distance from the **ref** point.

Example : to store the X axis work datum

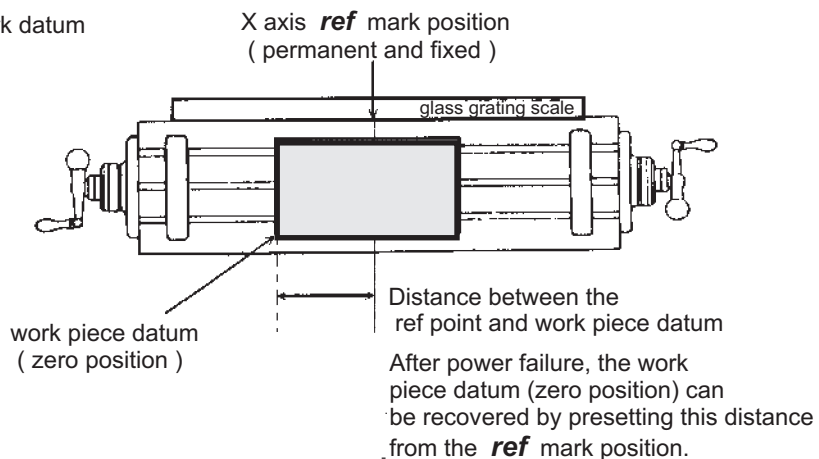

Operation : **RD-15S** provides one of the most easy-to-use **ref** datum memory function.

There is no need to store the relative distance between the **ref** mark and your work datum zero into the **RD-15S**, whenever you alter the zero position of **ABS** coordinate, such as by zeroing, centre find, coordinate preset or etc., **RD-15S** will automatically store the relative distance between **ABS** zero and the **ref** mark location into **RD-15S**'s memory.

In daily operation, operator simply needs to locate the **ref** mark position whenever they switch on the **RD-15S** to let it know where the **ref** mark position is, then **RD-15S** will automatically do the work datum storage on its' own . In the case of a power failure or the **RD-15S** being switched off, the operator can recover the work piece datum easily by using the **RECALL 0** procedure.

Find the scale's *ref* mark position (FIND REF)

function : In ref datum memory function, the **RD-15S** will automatically store the relative distance between the *ref* mark position and the work piece datum (zero position) whenever the operator alter the **ABS** zero position, such as zeroing, centre find, co-ordinate preset or etc...

Therefore, the **RD-15S** needs to store the *ref* mark position prior to any machining operation. So that the loss of the work piece datum (zero position) is avoided during any accidental or unexpected events, such as power failure or etc.. it is recommend that the operator finds the *ref* mark position using the (**FIND REF**) function whenever he switches on the **RD-15S**.

step 1 : To enter the ref function, select the **FIND REF** (find *ref* mark)

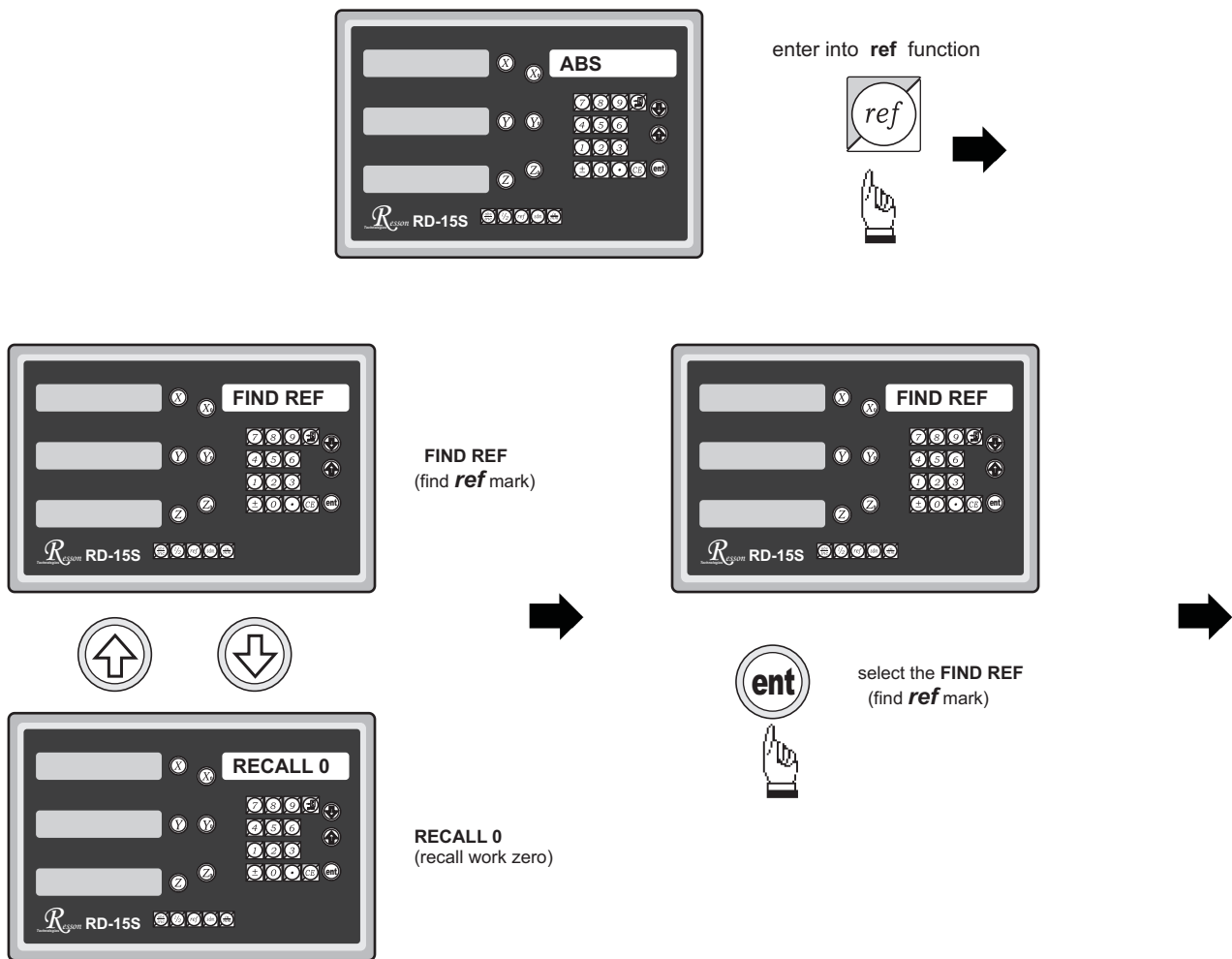

step 2 : select the axis of which *ref* mark needs to be found

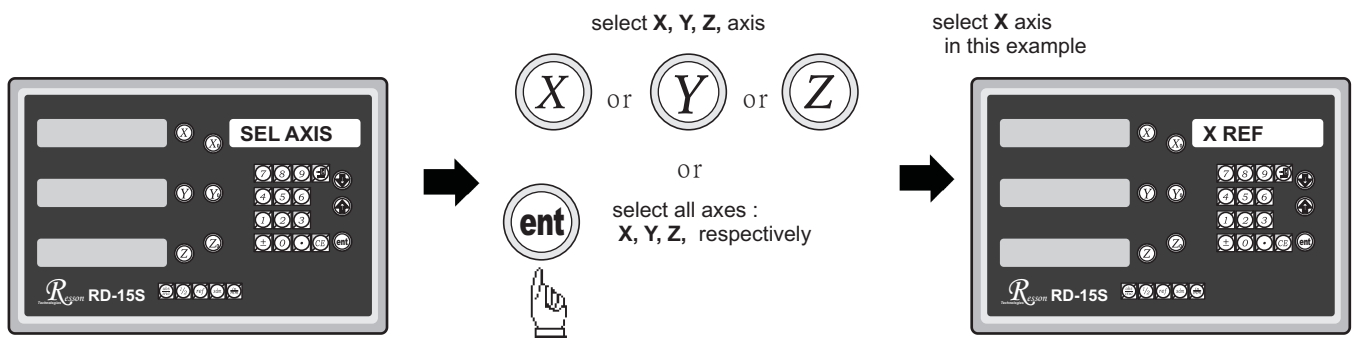

Find the scale's *ref* mark position (**FIND REF**)

step 3 : move the machine reader head across the length of the transducer until digits display in **RD-15S** start to count.

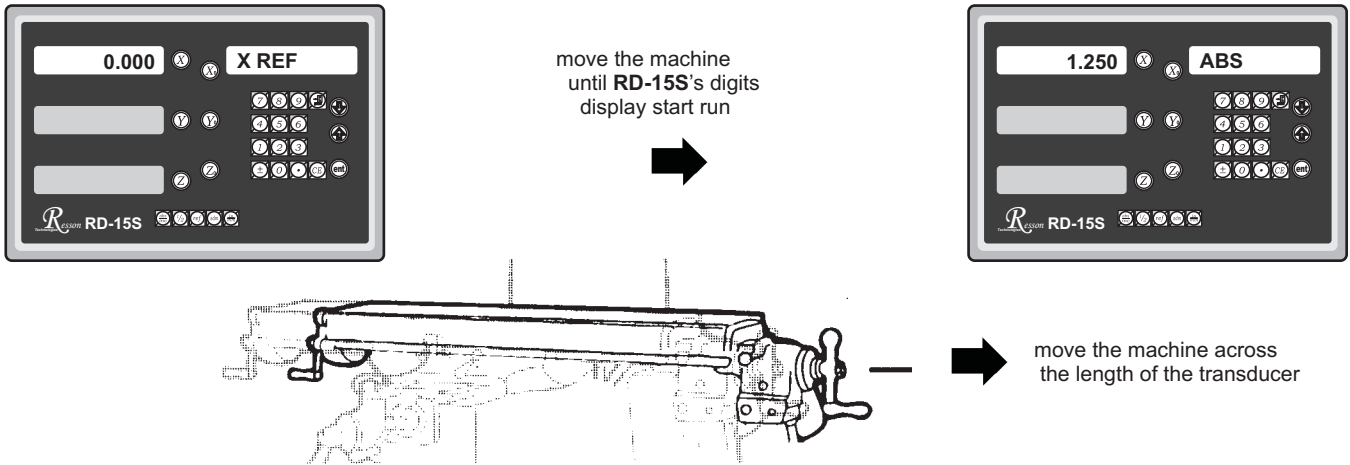

Recall the work datum zero (**RECALL 0**)

function : If the ref point is lost for any reason, the work piece datum can be recovered by **RECALL 0** function as follows:

step 1 : enter into the *ref* function, select the **RECALL 0** (recall work piece zero)

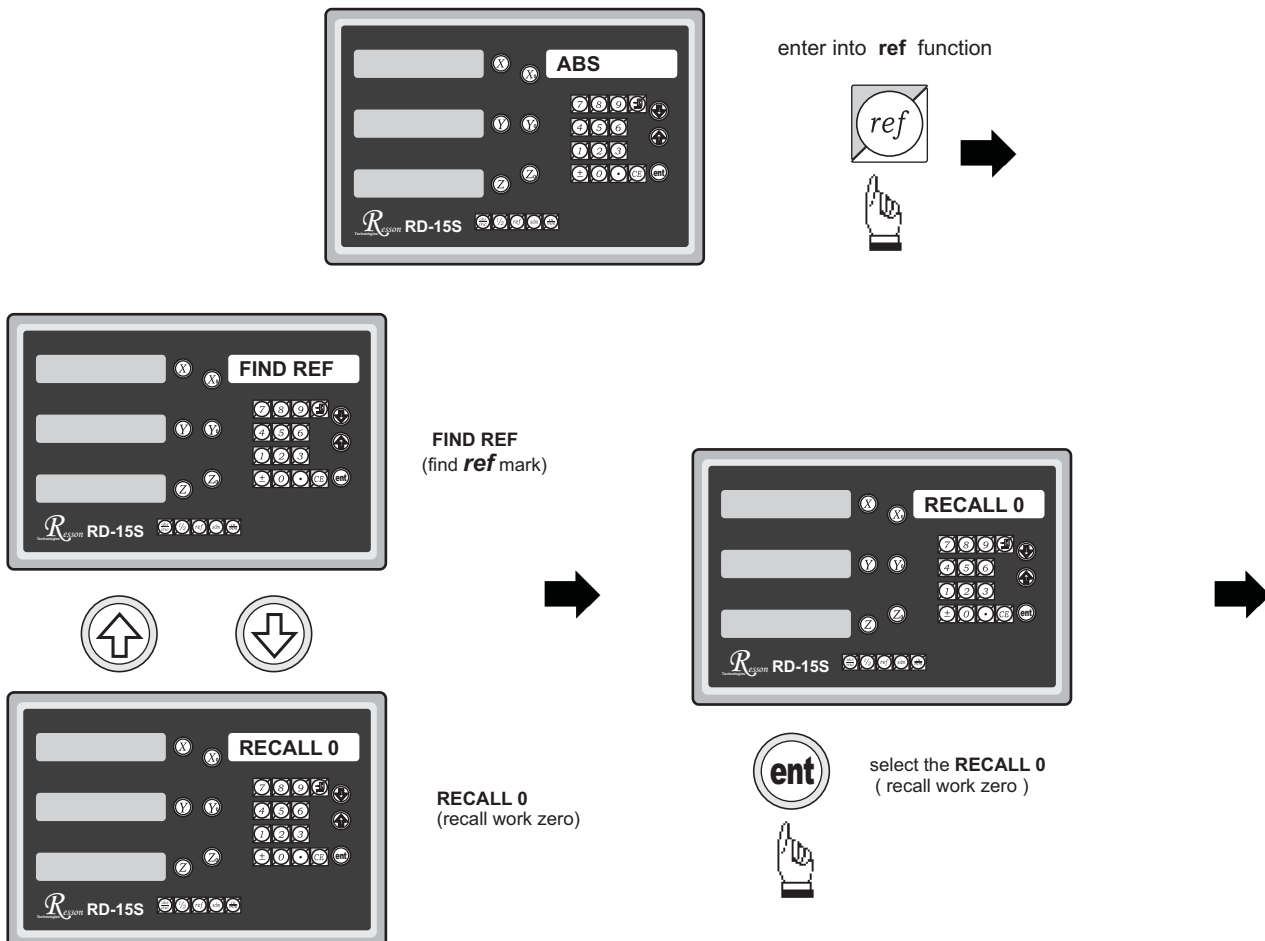

Recall the work datum zero (RECALL 0)

step 2 : select the axis of which work datum (zero position) needed to be recovered

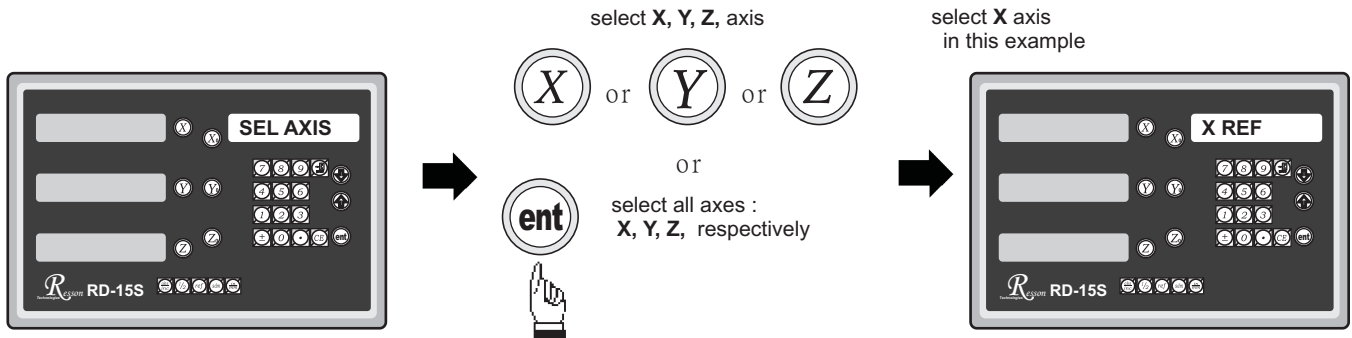

step 3 : move the machine across the length of the transducer until the RD-15S display starts to count, then the work piece datum is recovered

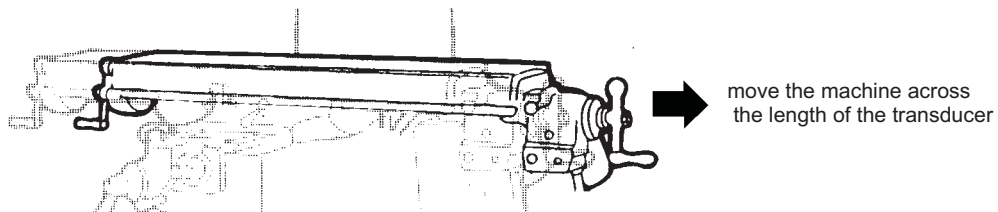

199 SubDatum Function

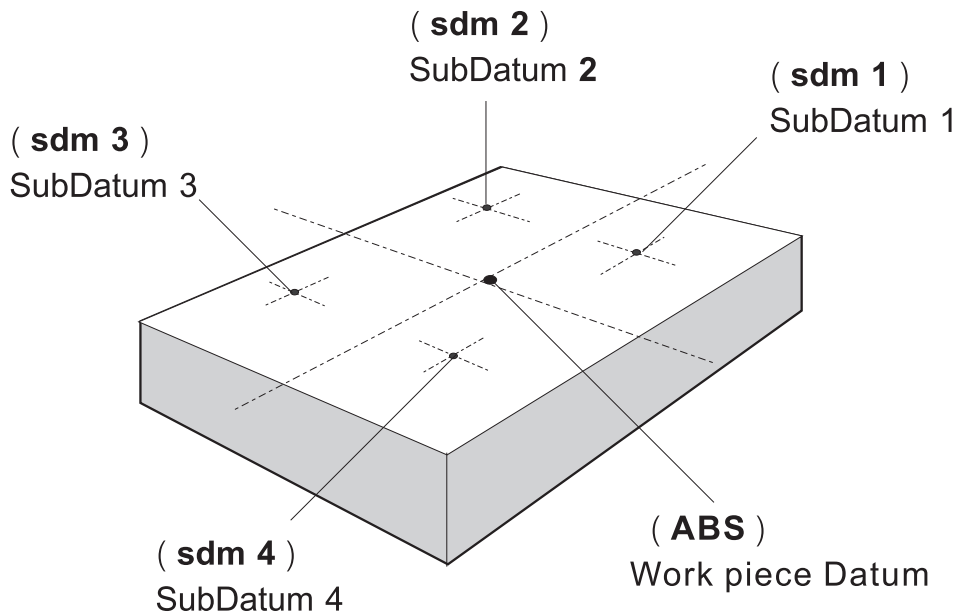
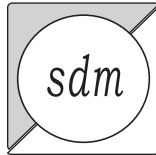

Purpose : Most **DRO** cabinet on the market provide just two set of work co-ordinates - **ABS/INC**. It was found that **ABS/INC** was inadequate and inconvenient to use, and, particularly in the case of complex machining or repetitive work, which needed more than just two sets of working co-ordinates.

ABS / INC operation has the following shortfalls :

- In much machining work, the work-piece machining dimensions are derived from more than two datums, therefore, the operator has to switch between **ABS** and **INC** to set up the machining datums time after time. This process is very time consuming and prone to error.
- In the case of batch machining of repetitive work, the operator has to set up and calculate all the machining positions time after time.

RD-15S provides a **199** subdatum (**SdM**) memory to cope with the shortfalls of **ABS/INC**. **SdM** function does not just simply provide **199** sets of **INC** co-ordinates, it is specially designed to provide much more convenient features for the operator to cope with repetitive work.



The difference between **INC** and **SdM** is as follows:.

1. **INC** is independent of **ABS** and will not follow any change in **ABS** zero point. All **SdM** co-ordinates are relative to the **ABS** coordinates, so, all **SdM** positions will move together when the **ABS** zero position changes.
2. All **SdM** relative distance data to **ABS** can be entered directly into **RD-15S** memory using the keypad. No need for any additional calculations.

SdM application in a work piece that has more than one datum.

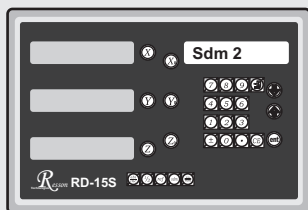
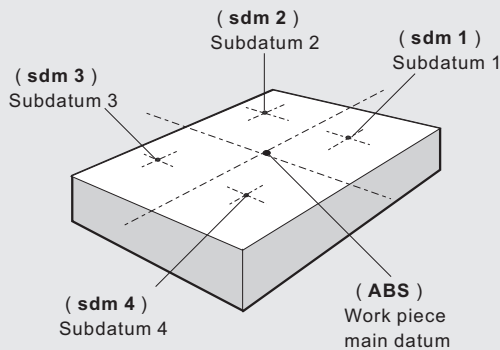
Operator can store all the work subdatums in **RD-15S**'s memory as per follows.







Operator then can switch between the subdatums directly by pressing key  or  No need to refer back to **ABS** coordinate and set up the subdatums from their relative distance from **ABS** point 

SdM application on the repetitive batch machining of parts

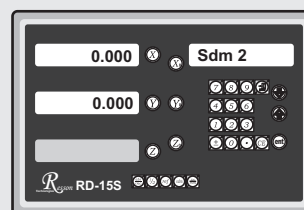
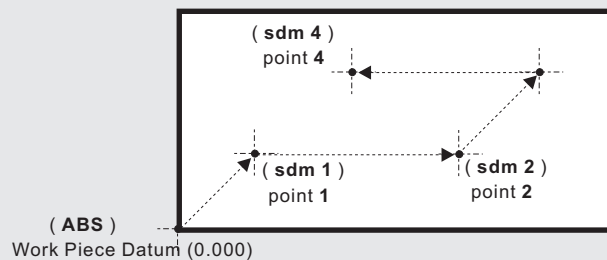
Because all **sdm** subdatums (0.000) are relative to **ABS** zero, so, for any repetitive work, the operator just needs to set up the first work piece zero at **ABS** and store the machining position in subdatum zero.

For anymore repetitive parts, just set up the 2nd, 3rd.. work piece zero at **ABS**, then all the machining positions will reappear



Press  or  key to go to machining points  move the machine to display = 0.000., then machining location reached

199 SubDatum function

Application example:

To set up four subdatum zero (**SdM 1** to **SdM 4**) the following two methods can be used

- Either 1. Move machine to required subdatum position, then zero **SdM** display coordinates
 Or 2. Directly key in the **SdM** zero position co-ordinates (co-ordinate relative to **ABS** zero)

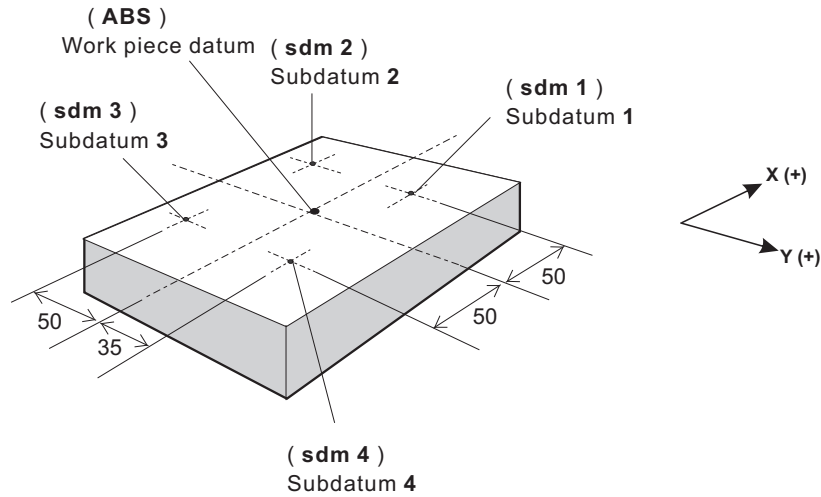

Method 1 : Move machine to required subdatum position, then zero SdM display coordinate

Set up the work piece datum in **ABS** co-ordinate, move the machine to the required subdatum position, then zero **SdM** display co-ordinate.

Step 1 : Set up the work piece datum in **ABS** co-ordinate

Switch to **ABS** coordinate display

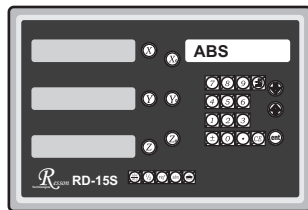

Locate the tool at work piece datum point

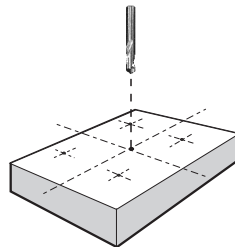

Set this point to **ZERO**

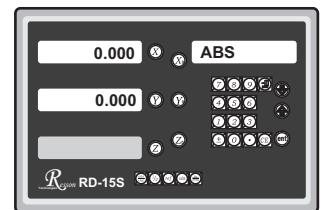
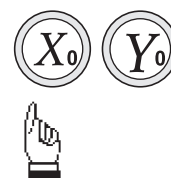

Step 2 : Set up the subdatum point 1 (**sdm1**)

Locate the tool at subdatum point 1 (**sdm 1**) :
X=50.000, Y=35.000

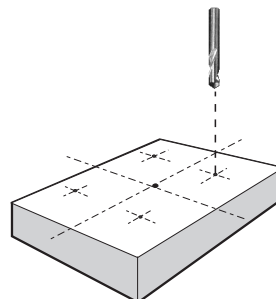
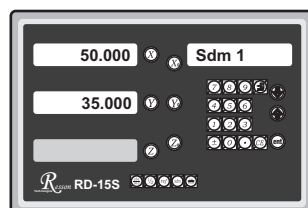

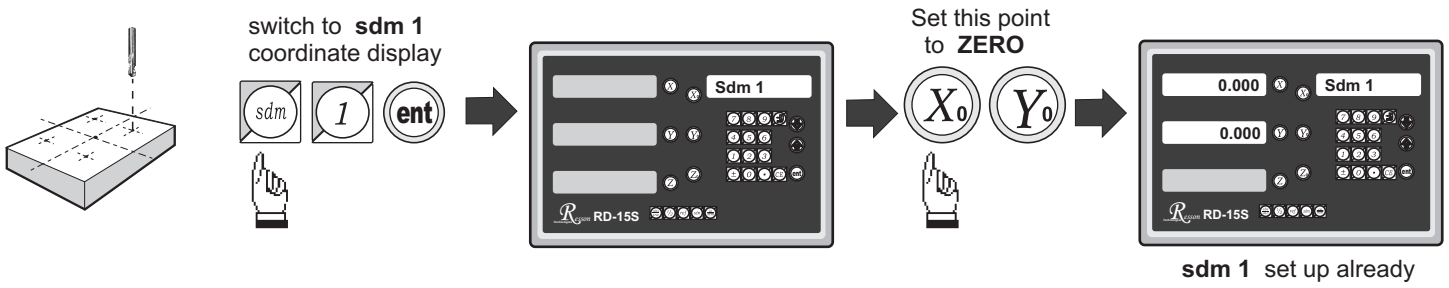

Step 3 : Set up the subdatum point 2 (sdm 2)

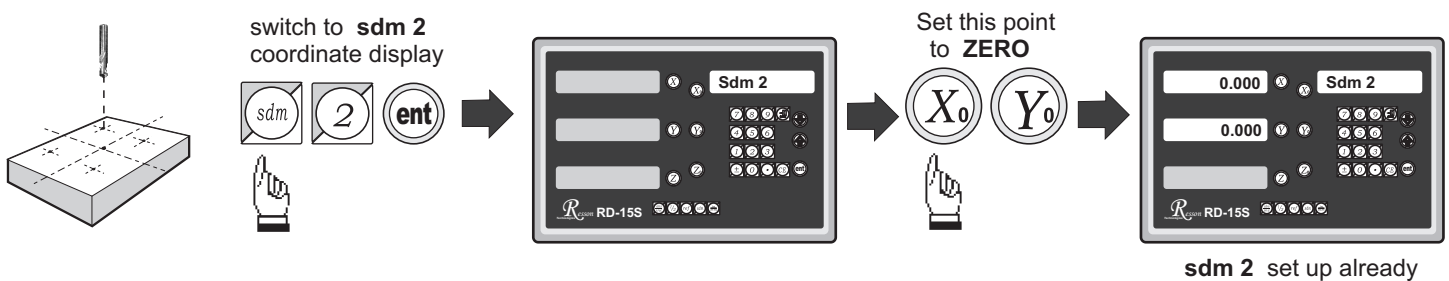
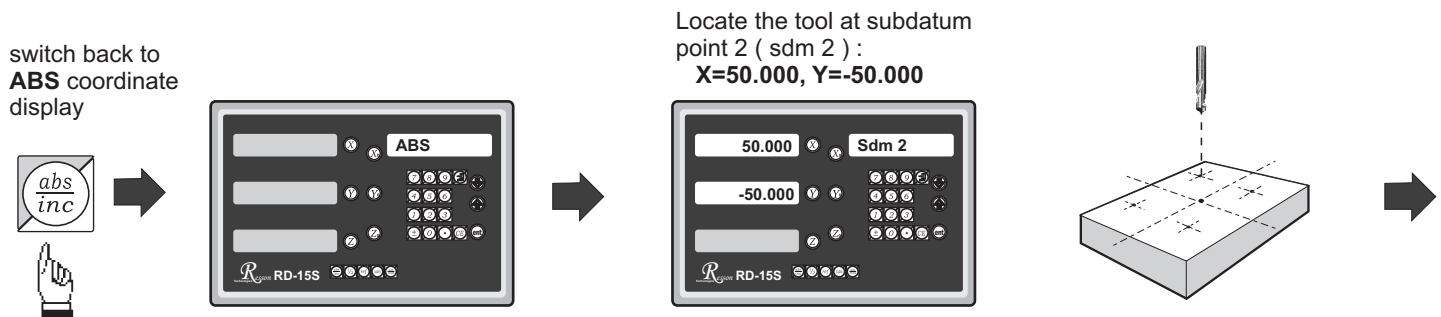

Step 4 : Set up the subdatum point 3 (sdm 3)

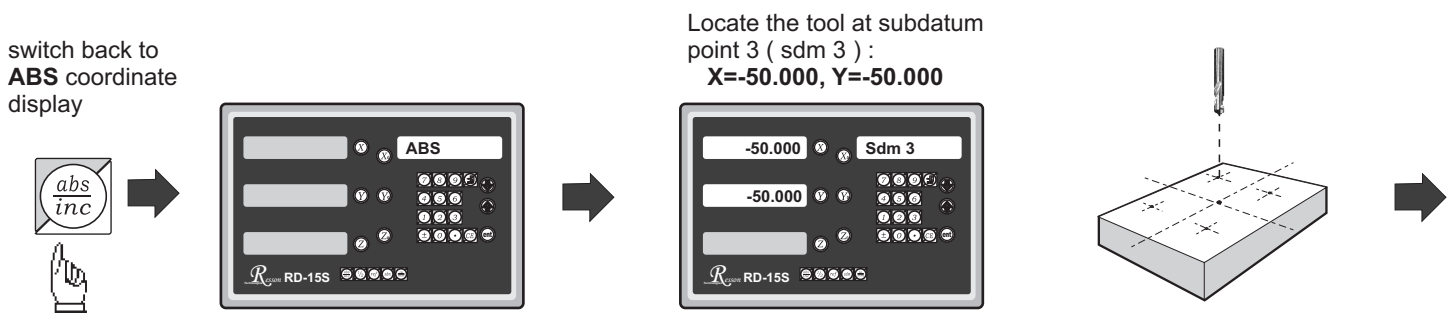

199 SubDatum function

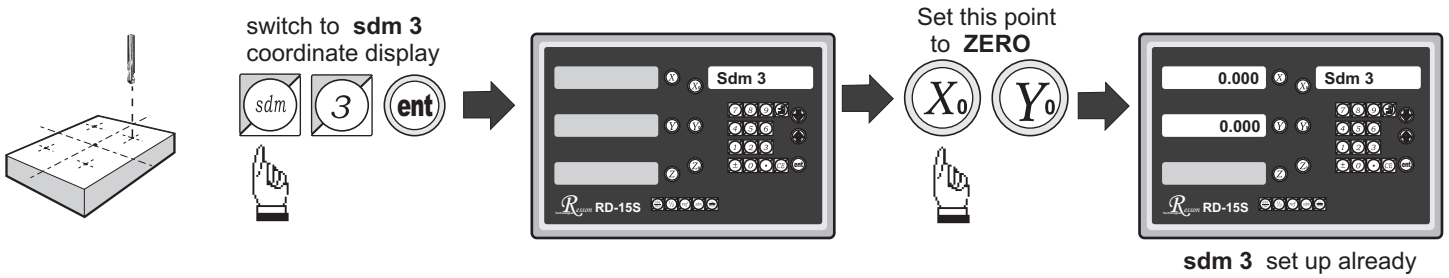

Step 5 : Set up the subdatum point 4 (sdm 4)

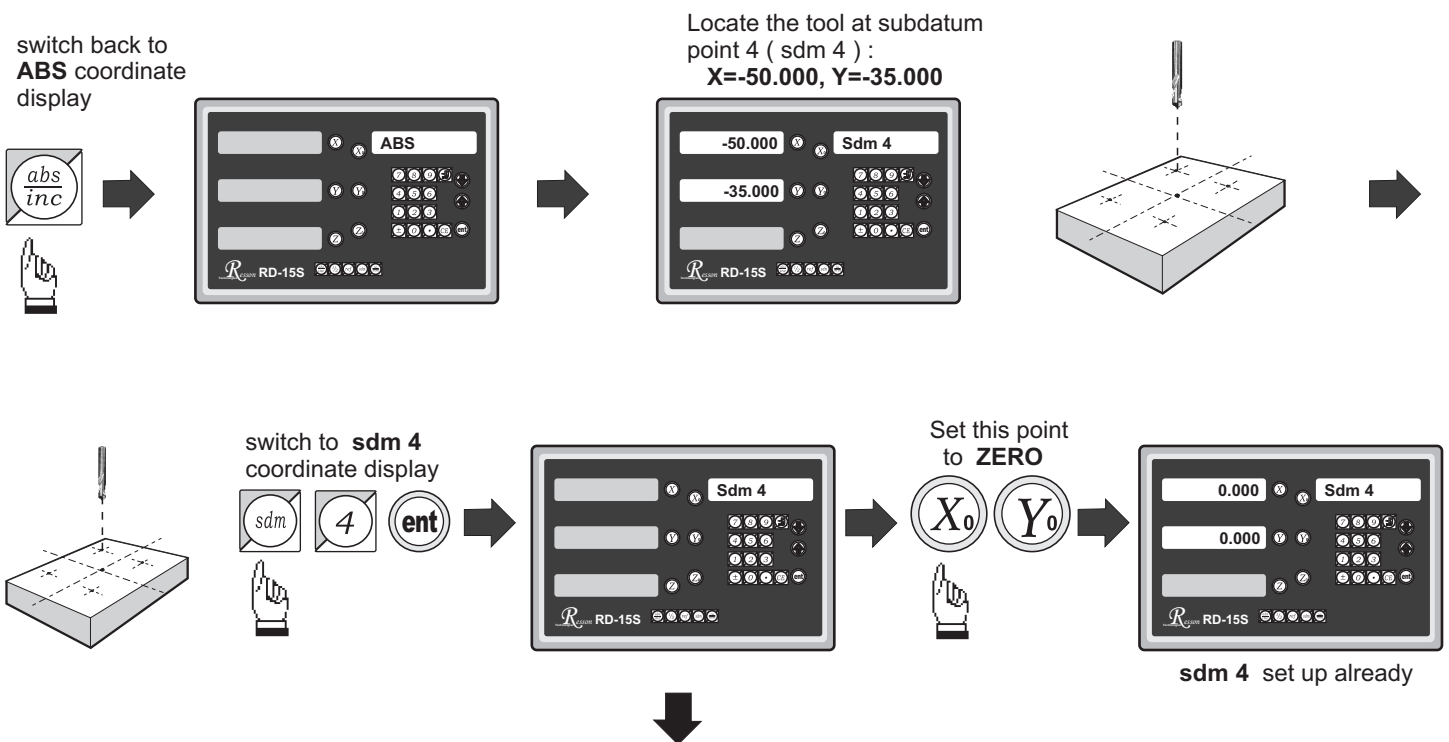

All the four subdatum points have already been set up

Operator can or to directly switch to the required subdatum (sdm) coordinate

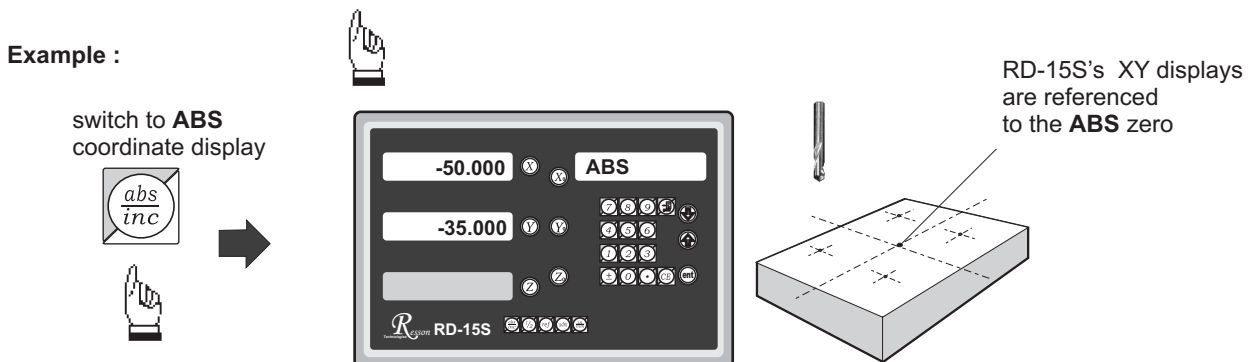

switch to next (**up**)
sdm coordinate display

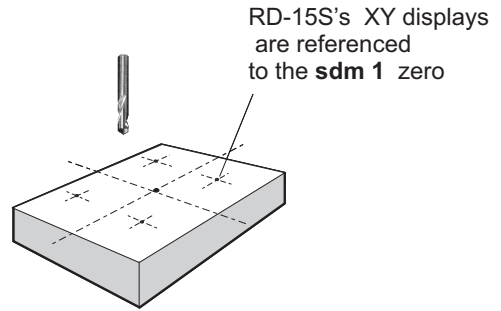
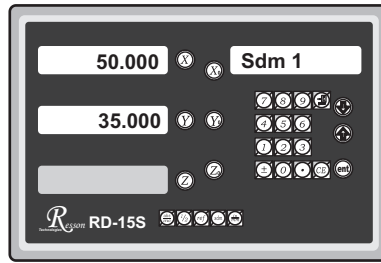

switch to next (**up**)
sdm coordinate display

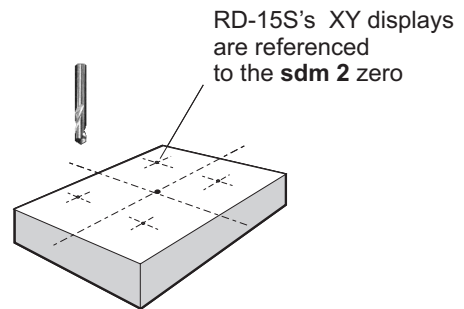
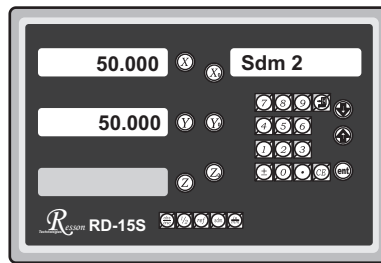

switch to previous (**down**)
sdm coordinate display

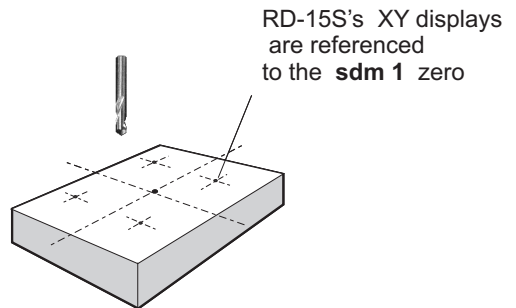
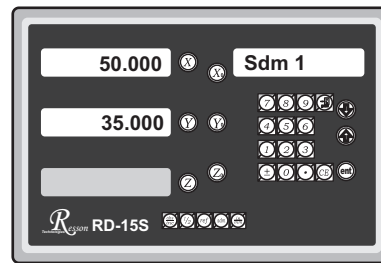

199 SubDatum function

In a case where many subdatum (sdm) points need to be set up, the operator will find that the method of **direct keying in the of Sdm zero position co-ordinates (co-ordinate relative to ABS zero)** is much quicker and less prone to error.

Mthethod 2 : Direct keying in the of Sdm zero position co-ordinate (co-ordinate relative to ABS zero)

Set up the work piece datum (ZERO) at ABS co-ordinate, then move the tool located at the work piece datum (ABS zero point) and directly key in all subdatum point co-ordinates (the relative position to ABS zero) using the keypad.

Step 1 : Set up the work piece datum in ABS coordinate

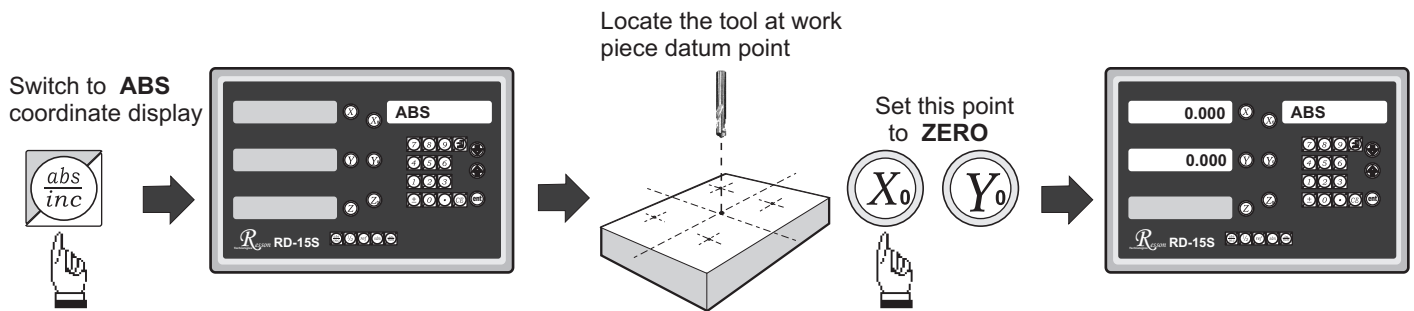

Step 2 : Set up the subdatum point 1 (sdm 1)

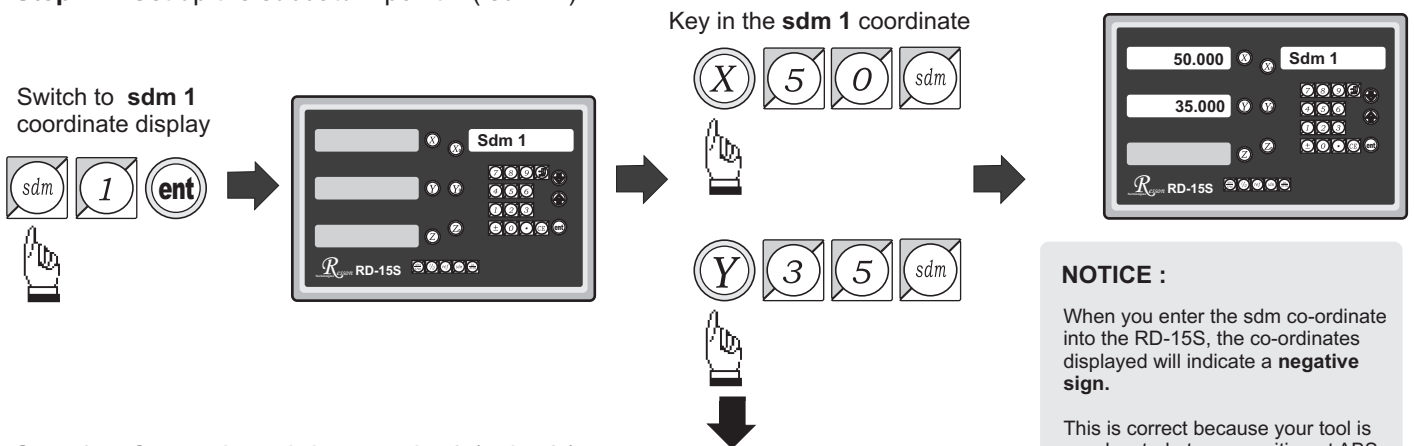

Step 3 : Set up the subdatum point 2 (sdm 2)

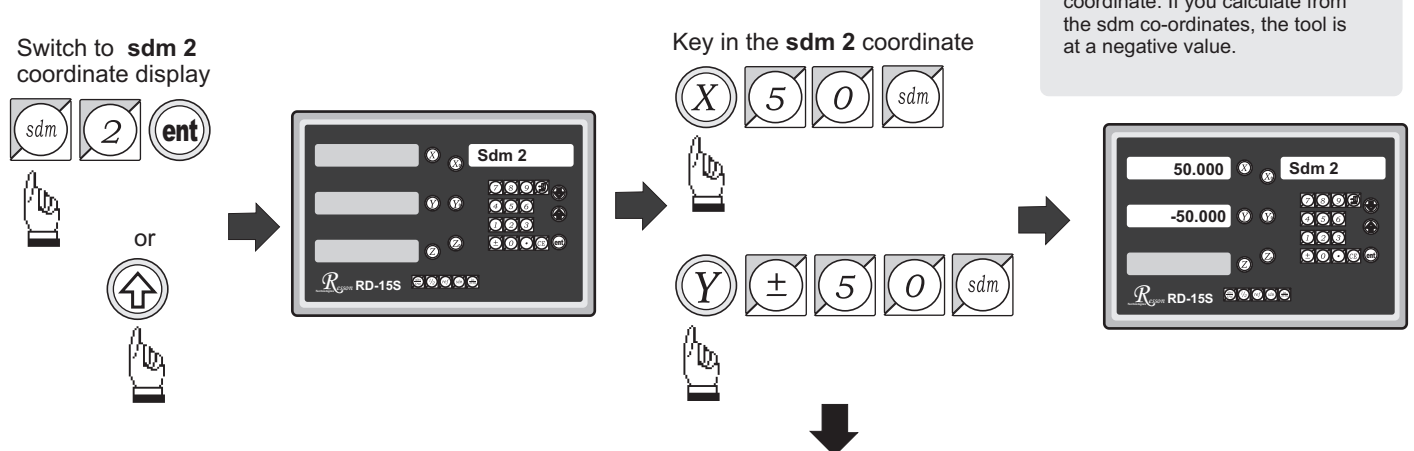

Step 4 : Set up the subdatum point 3 (sdm 3)

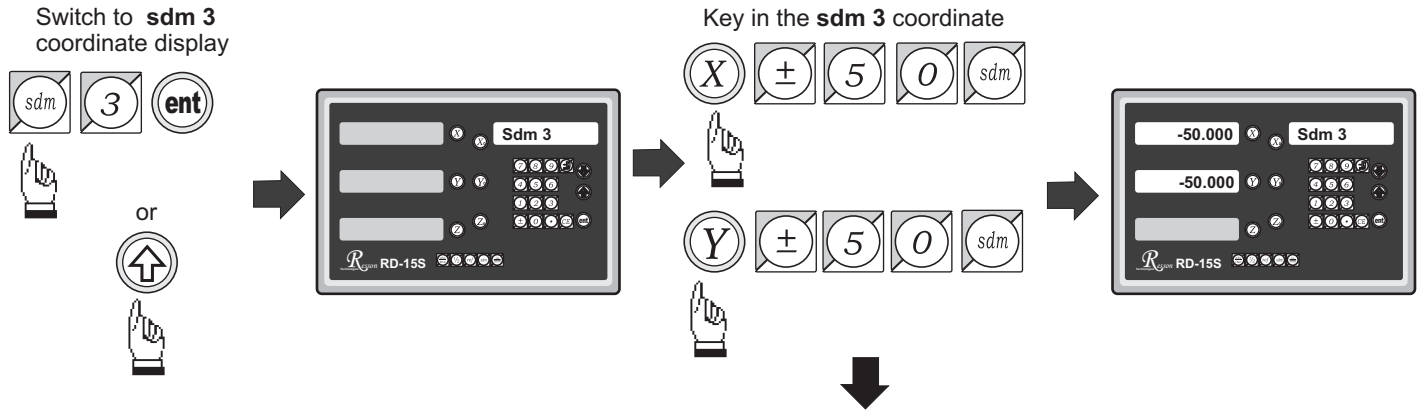

Step 5 : Set up the subdatum point 4 (sdm 4)

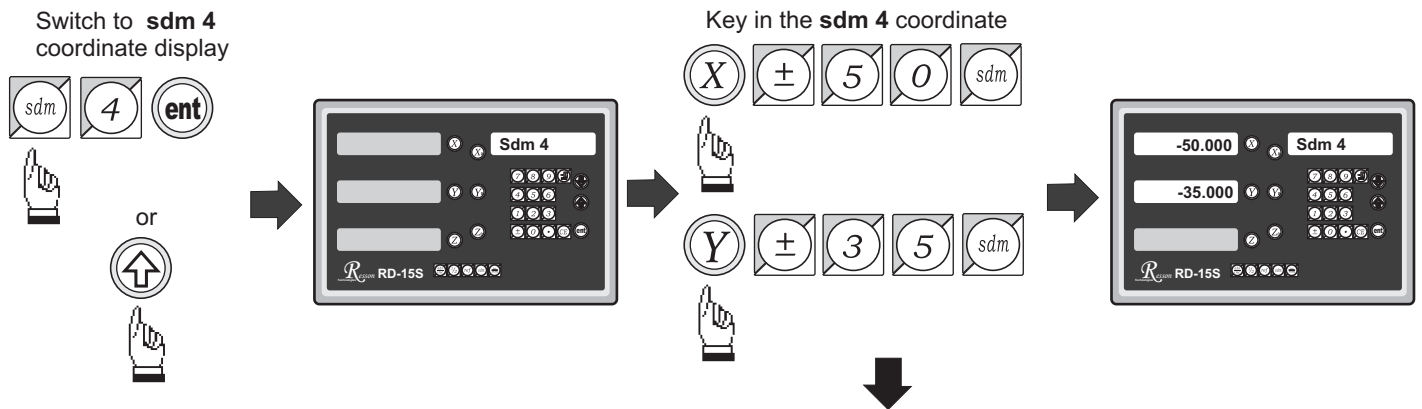

All the four subdatum points have already been set up

Operator can or to directly switch to the required subdatum (sdm) coordinate



Example :

switch to **ABS** coordinate display

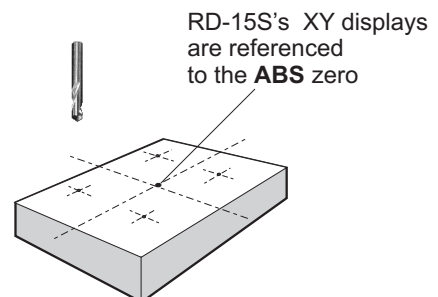
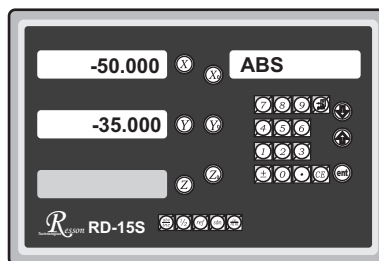
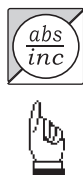

199 SubDatum function

switch to next (up)
sdm coordinate display

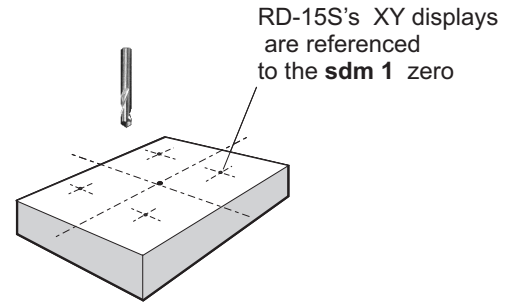
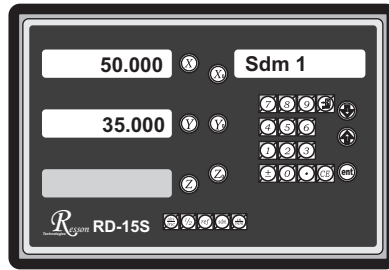
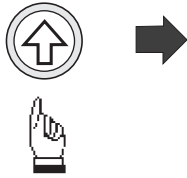

switch to next (up)
sdm coordinate display

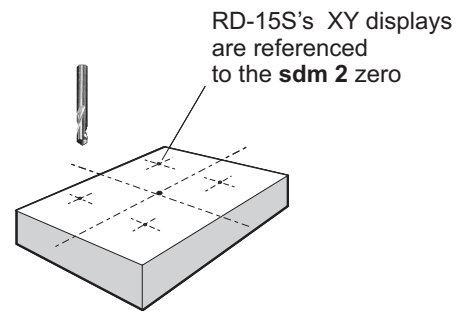
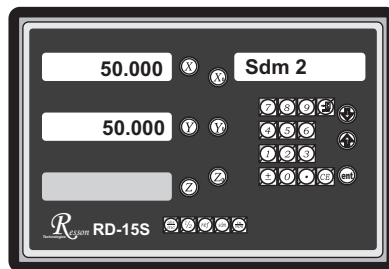
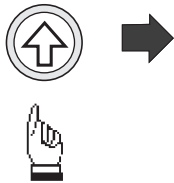

switch to previous (down)
sdm coordinate display

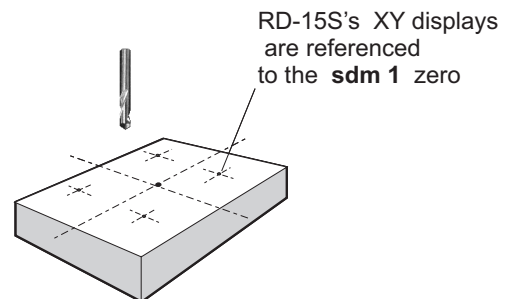
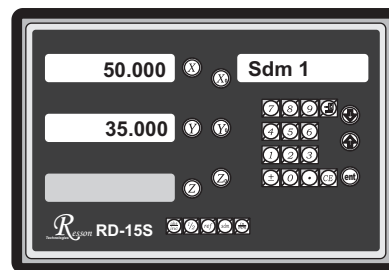
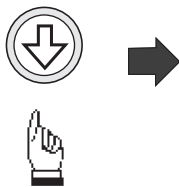

RD-15S Parameters Setup

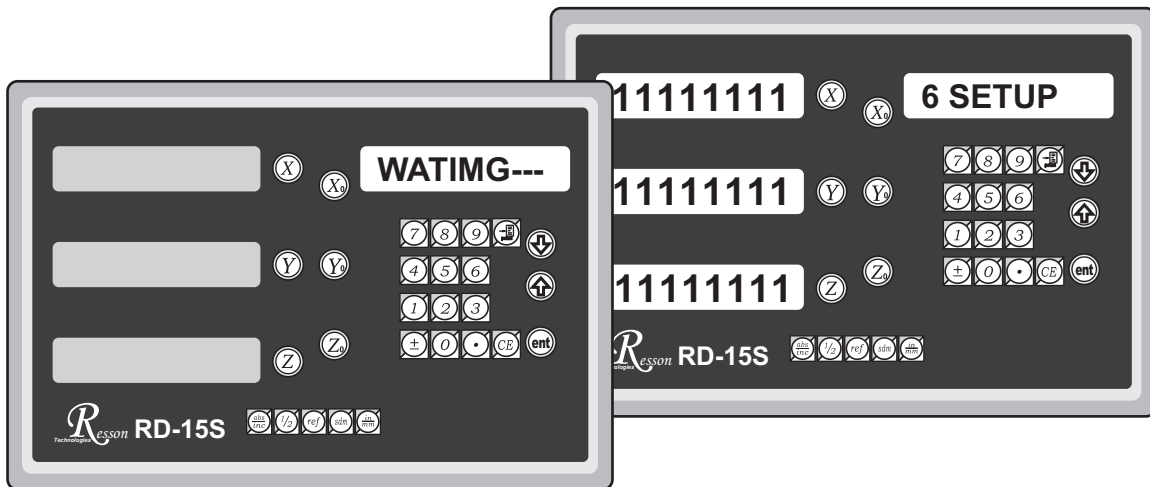

- BAUD SET set up RS232 transmission baud.
- BEEP ON/OFF turn on/off printer.
- BEEP ON/OFF turn on/off beeper.
- RESOLUTE set up Linear scale resolution.
- CP ERROR compensate Linear scale error
- LINEAR P compensate linear error.
- NL ERROR compensate nonlinear error (point compensation)
- DIRECT set up direction.
- EXIT end and exit.

Reset display's original parameter (RESET)

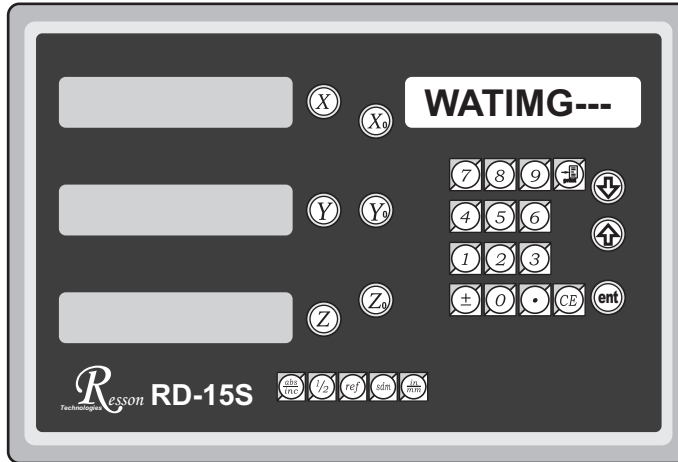

When the DRO is under the impact of abnormal voltage, or user's improper operation that cause parameter setting in error, it needs to default simple working parameters by resetting them to default value from memory. Yet, before parameter reset, check if there is any parameter value set in already; if so, write down the setting data and set it up after reset.

Operation steps:

- 1) . Turn off the DRO power.
- 2) . Turn on the DRO; when “11111111” test signal is shown in the display window, press “0” and the display start performing “reset”.

While turning on the display,
it will perform self diagnosis
and test; press

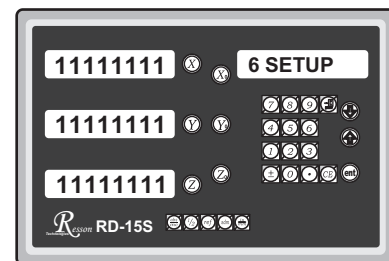

- 3). 1. When parameters reset, “WATING” will show on the display.

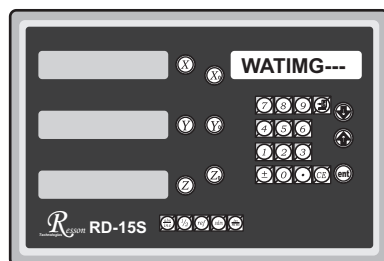

“WAITING --” is shown as
parameter reset is underway.

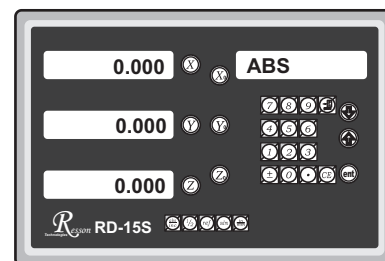

After coming backing to normal mode,
the parameter reset process is complete.

Set up new parameters in display (SETUP)

When DRO-change IC is under the impact of abnormal voltage or improper operation, which cause the default disturbed; or user wants to change production process and needs to modify the default value, it needs to set up DRO and reset function values in memory.

DRO in the display and related key locations in the SETUP process:

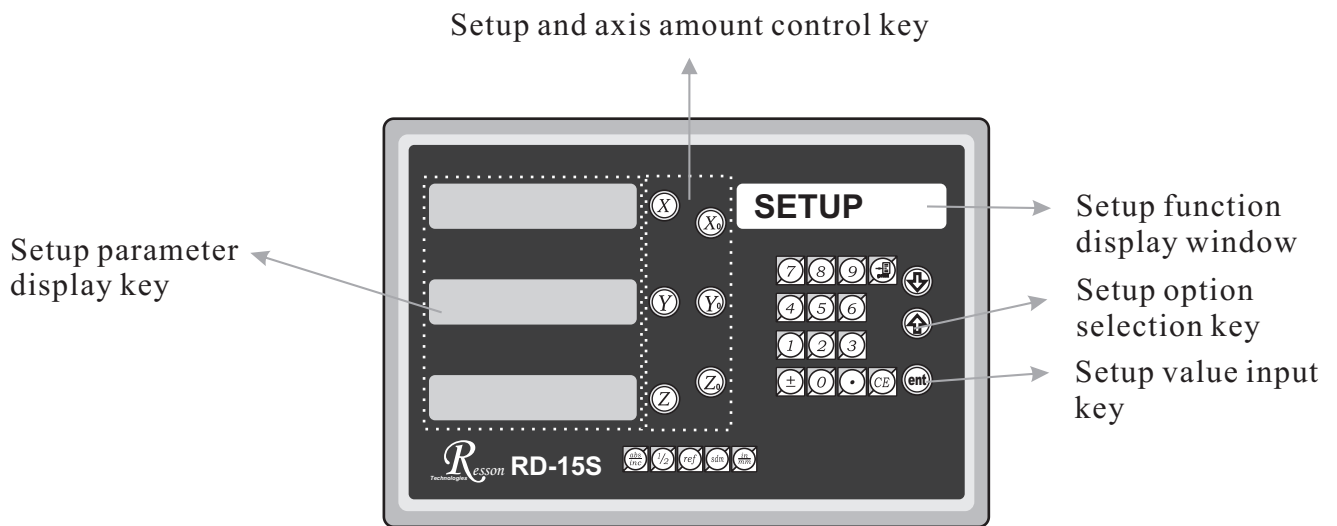

Operation steps:

- 1) 1. Turn off the DRO power.
- 2) Turn on the DRO; when self-diagnosis test signal is shown in the display window, press  and the display start performing “setup”

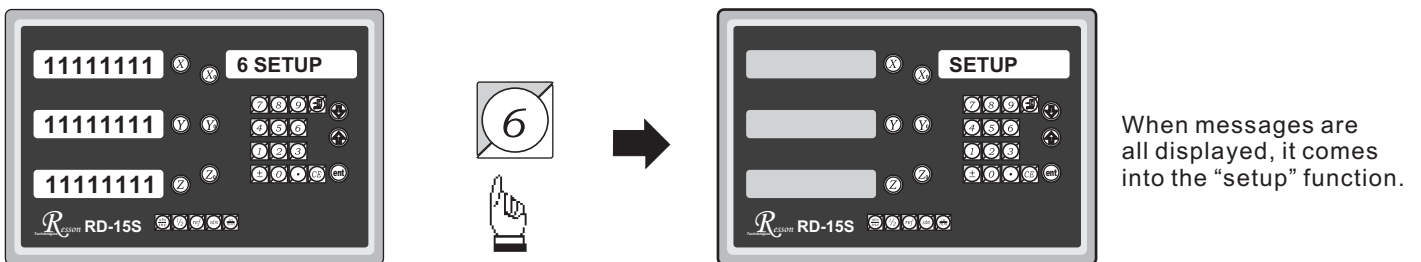

The setup procedure is designed to option menu mode; the Definition List facilitates user to apply the following options.

Parameters Setup

The first layer functions are, in turn, defined as below:

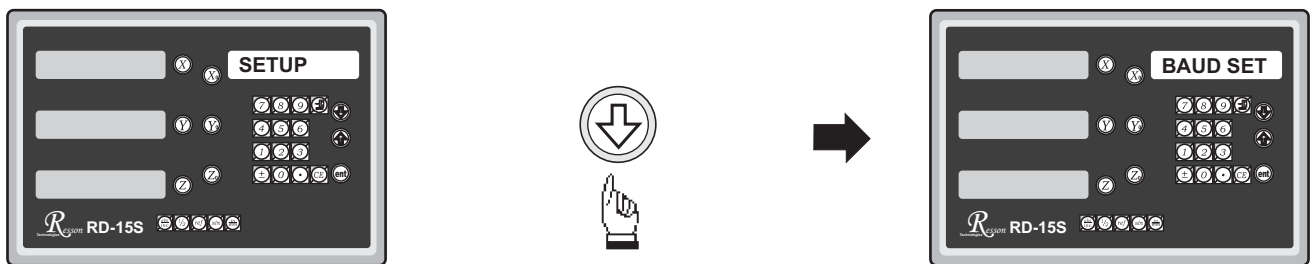

- BAUD SET set up RS232 transmission baud.
- BEEP ON/OFF turn on/off printer.
- BEEP ON/OFF turn on/off beeper.
- RESOLUTE set up Linear scale resolution.
- CP ERROR compensate Linear scale error
- LINEAR P compensate linear error.
- NL ERROR compensate nonlinear error (point compensation)
- DIRECT set up direction.
- EXIT end and exit.

3) Press  to “BAUD SET”.

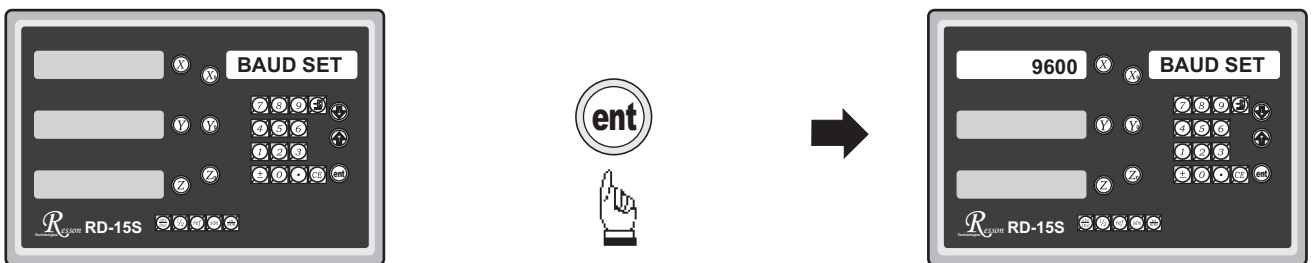

Press  to enter the setting of RS232 transmission baud.



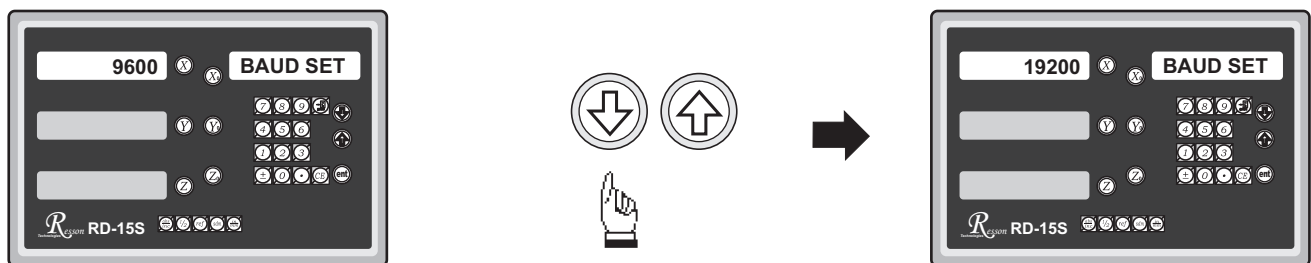

Press  or  to select the correct baud speed from 1200/2400/4800/9600/19200/57600.



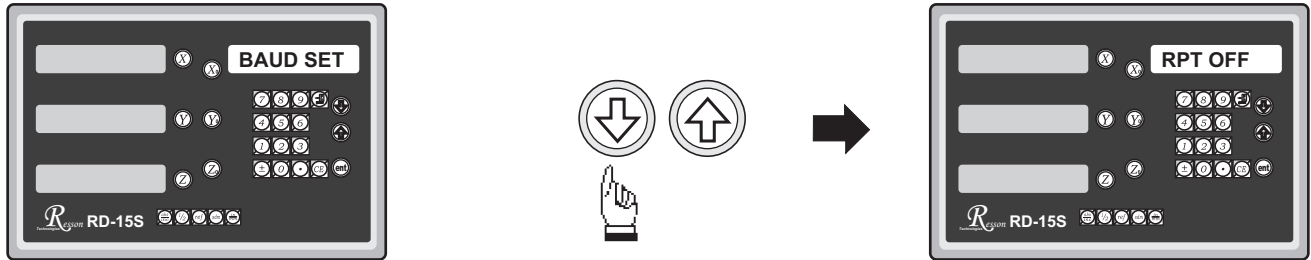

After baud speed is selected, press  to end up this setting function.

4) Press  or  and move to “PRT ON/OFF”.

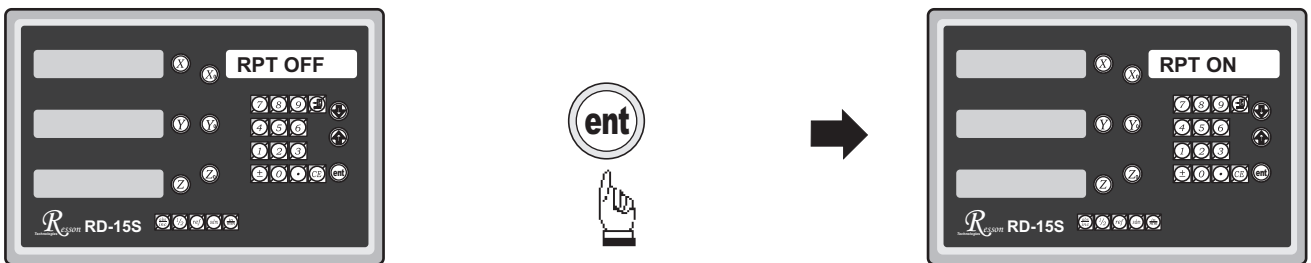

Directly press  to change over OFF & ON.



5) Press  or  and move to “BEEP ON/OFF”.

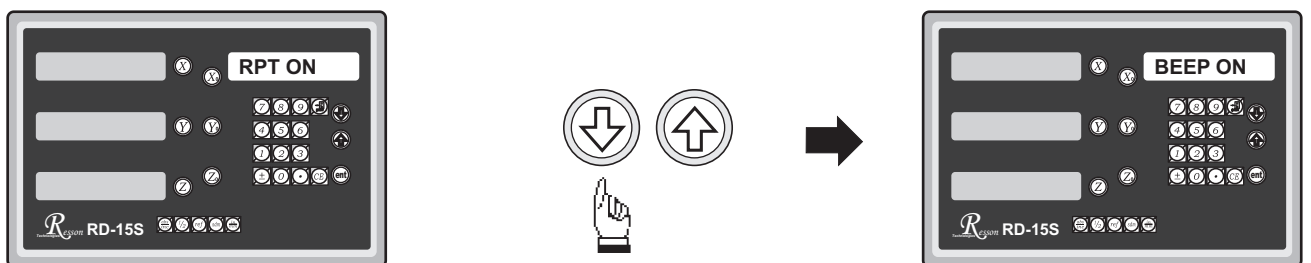

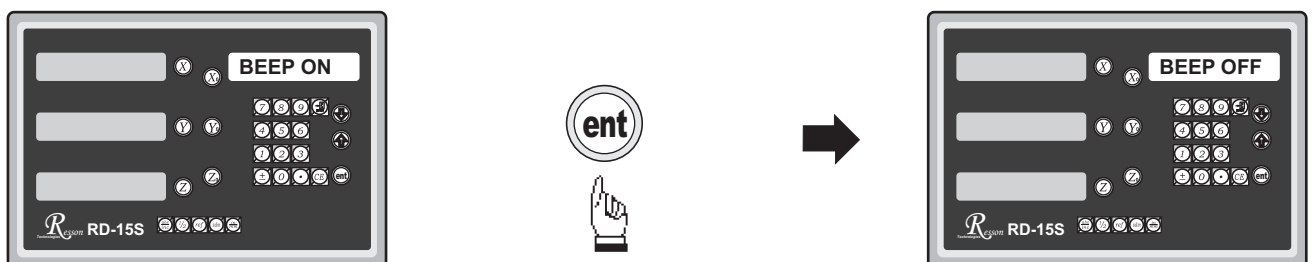

Directly press  to change over OFF or ON.

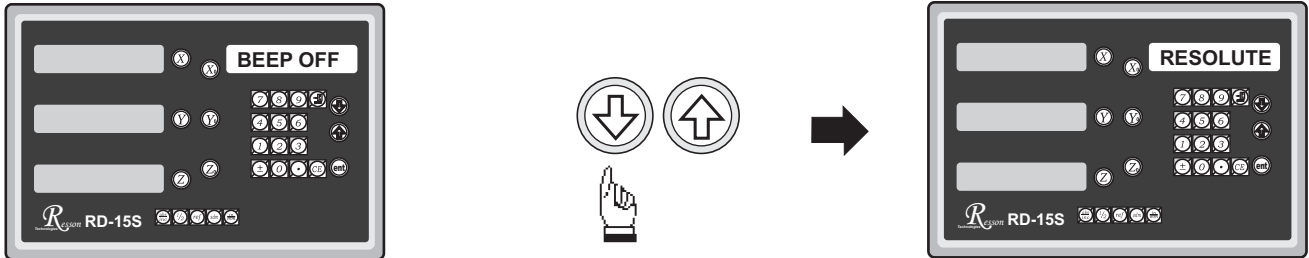

Parameters Setup

6) Press  or  and move to “RESOLUTE”.



Press  to enter the linear scale resolute setup.

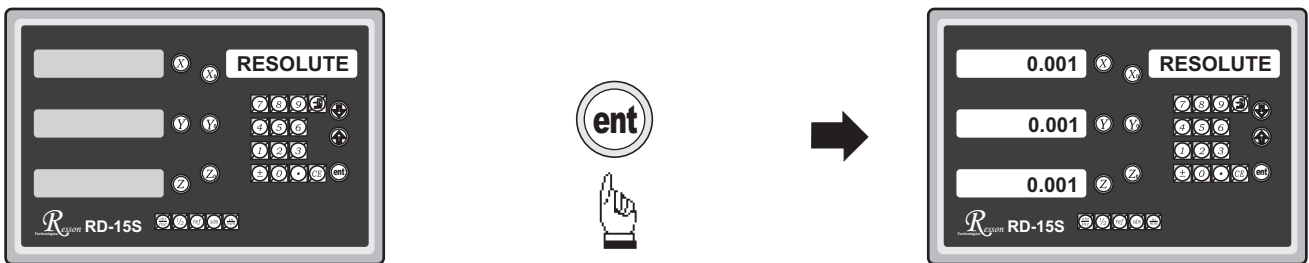

Press the axis going to be changed:  ,  , 

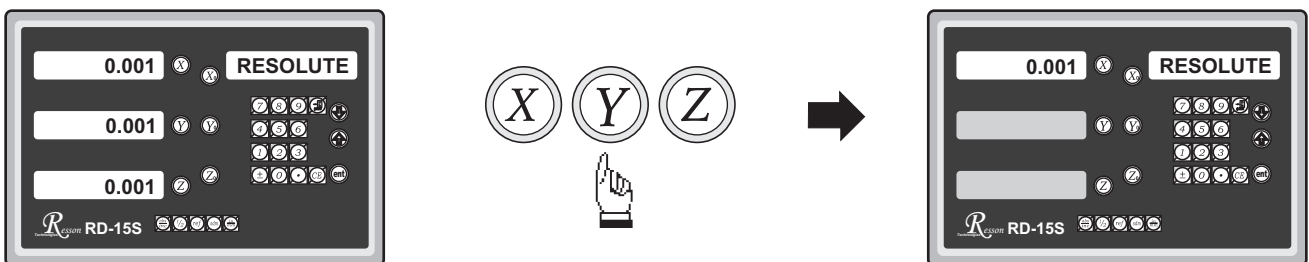

Press  or  to switch to the correct resolution value from 0.01/0.005/0.002/0.001/0.0005/0.0002/0.0001.

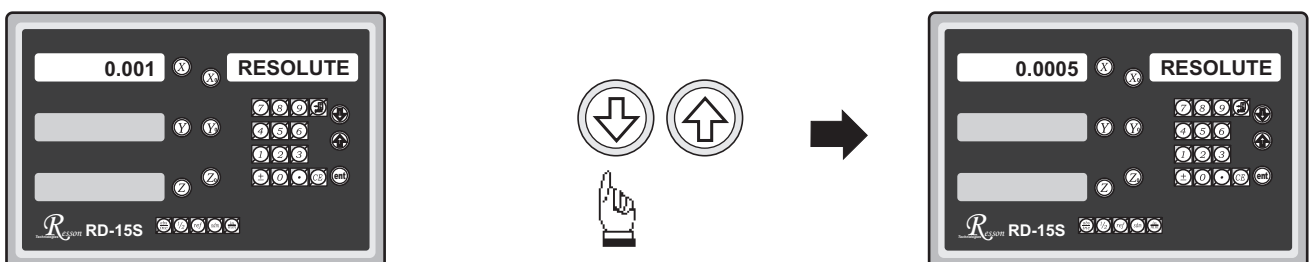

Press **ent** to end up this axis's setup

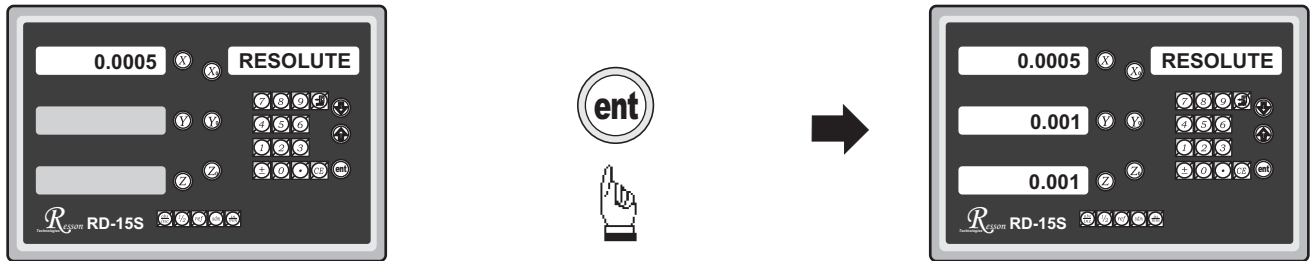

Then, press **ent** to end up the linear scale resolute setup procedure.

7) Press **↓** or **↑** to “CP ERROR” (error compensation).

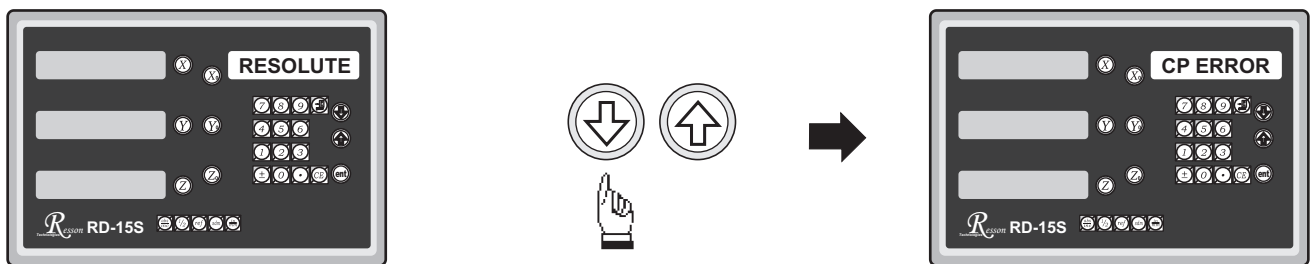

Press **ent** to enter the compensation setup; you can press **↓** or **↑** to switch between the “LINEAR P” (linear compensation) mode and “NL ERROR” (nonlinear compensation) mode; choose one alternatively.

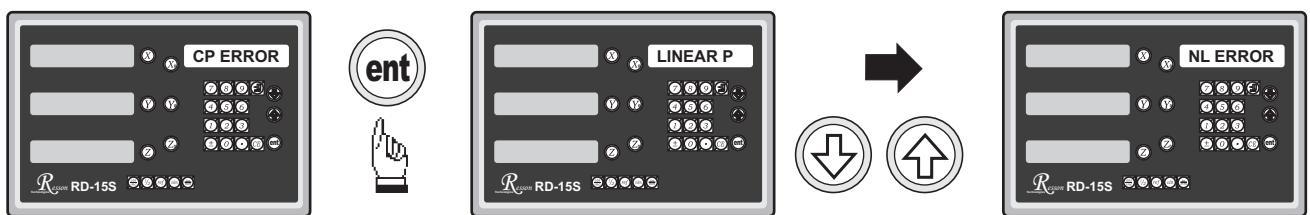

While selecting “LINEAR P”, press **ent** to enter the linear compensation process.

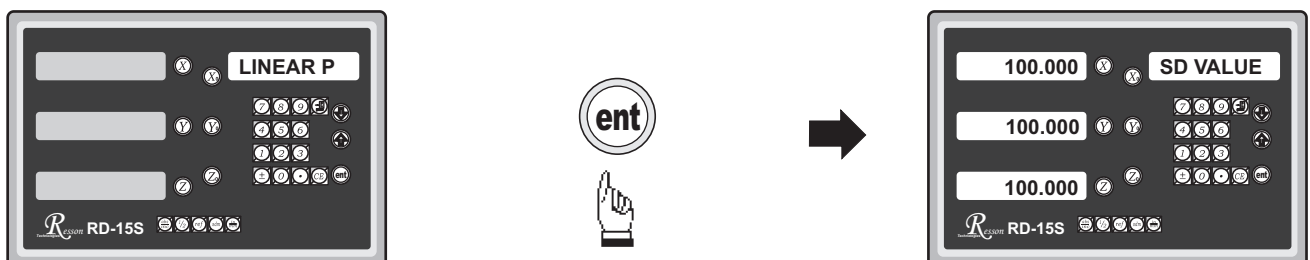

Parameters Setup

Press the axis **(X)** , **(Y)** or **(Z)** under compensation.

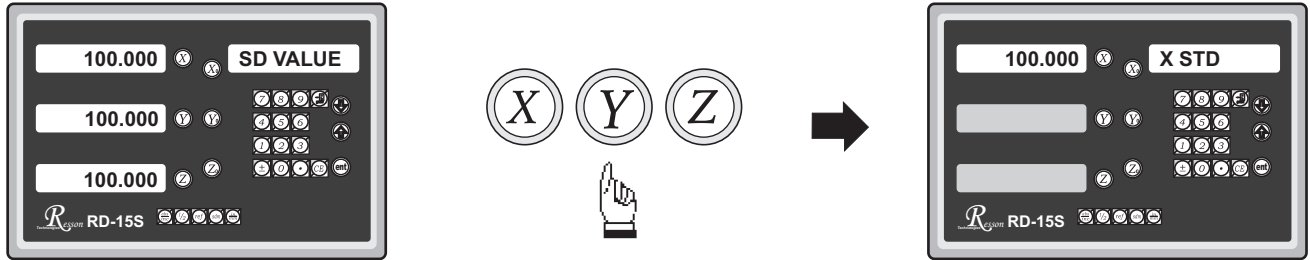

Input the length measured and press **(ent)** .



Input the actual length and press **(ent)** .

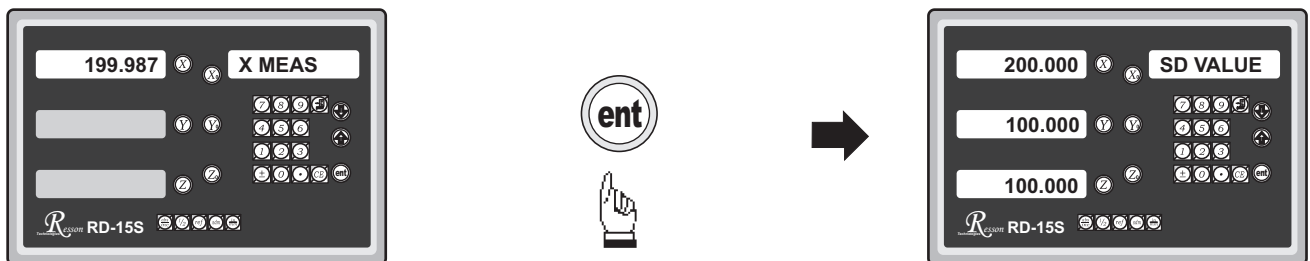

Press other axis **(Y)** or **(Z)** under change and follow the above procedure to operate;
after the compensation procedure is done, press **(ent)** to end up the compensation of linear scale.

Press or to switch to “NL ERROR” (nonlinear compensation).

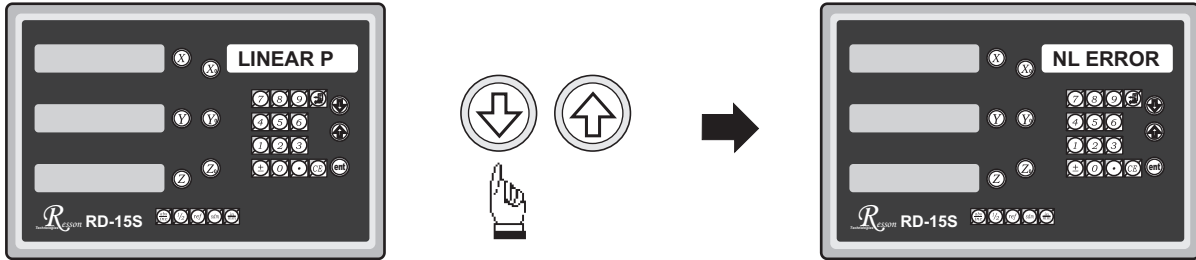

Press to enter the nonlinear compensation setup.

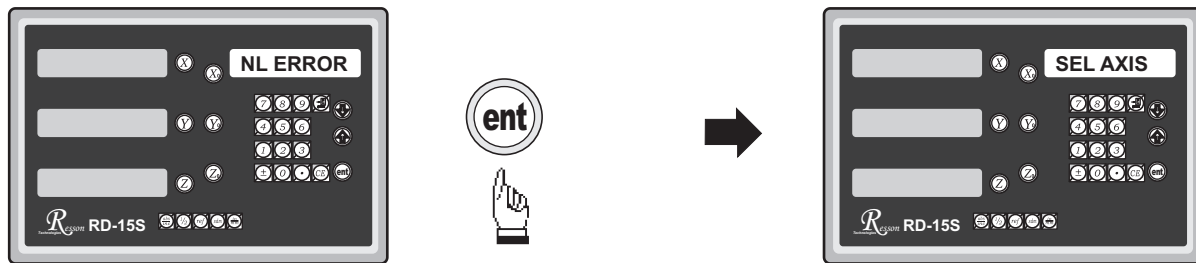

Press the axis , or under compensation.

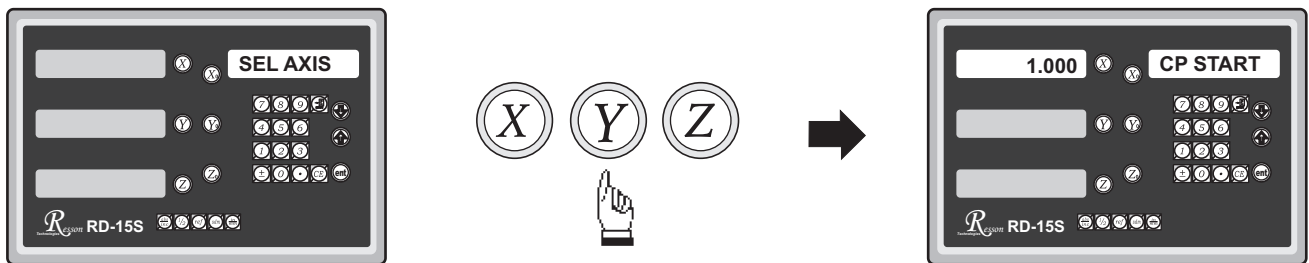

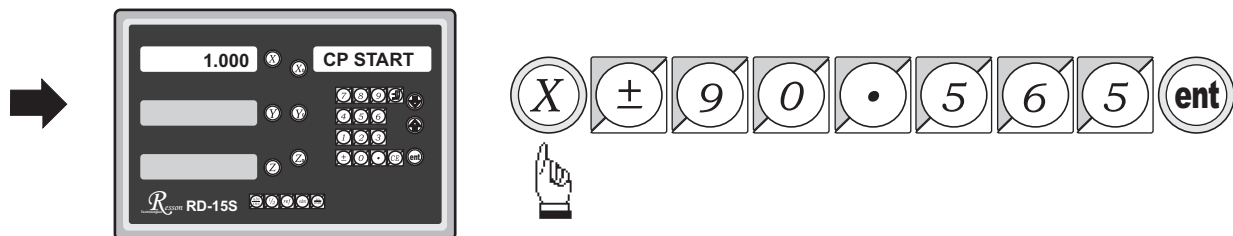

Input CP START







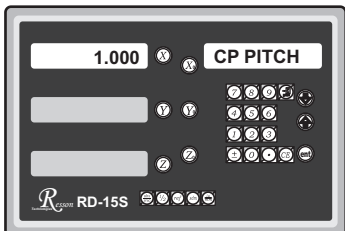

Parameters Setup

Next step





Input CP START











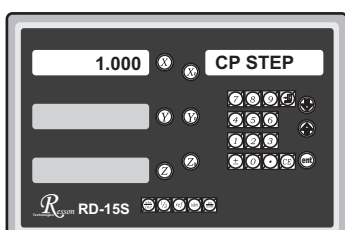



Next step



Input CP STEP





After entering the “Point 1” status, press the up/down key to select the measuring result at the point selected.

Input the measuring result.

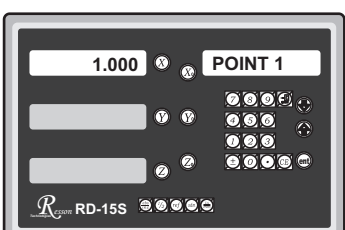

----- The measuring result -

After all data inputs are done, press CE to exit.





Press up/down key till EXIT appears.















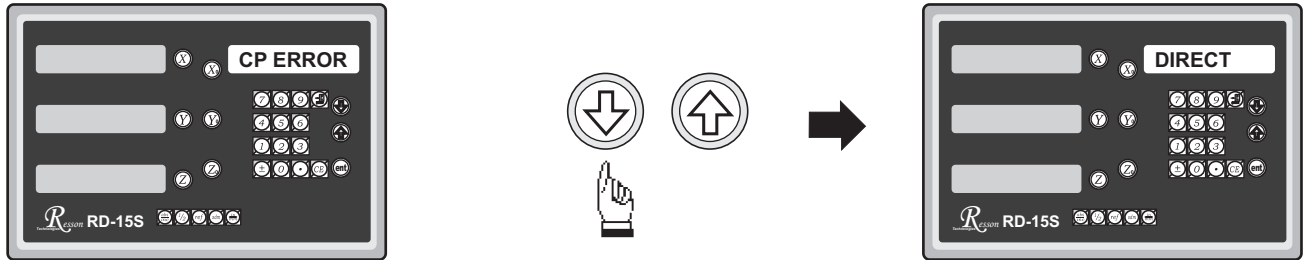

If use the error compensation function, you must turn off the DRO then power on the DRO again, otherwise your compensated value will invalid.

8) Press  or  to move the “DIRECT” (direction setup).

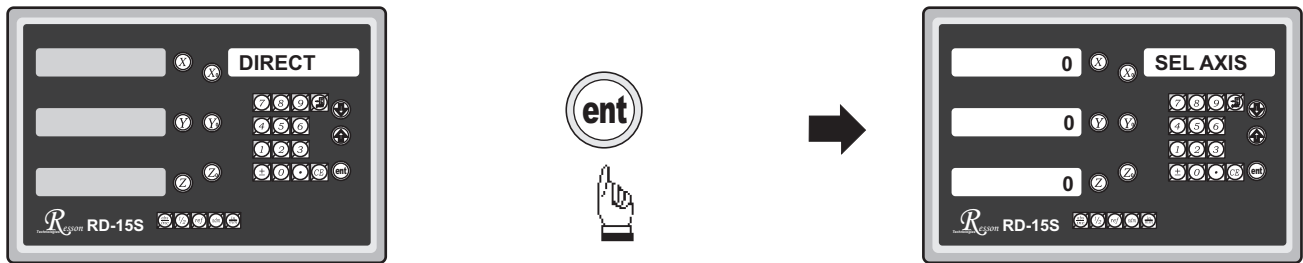

Press  to enter direction setup mode. “0” means in positive direction whereas “1” means the negative direction.



Press  or  to set up X-axis to “1” (negative direction); and do it to Y- & Z-axis similarly.

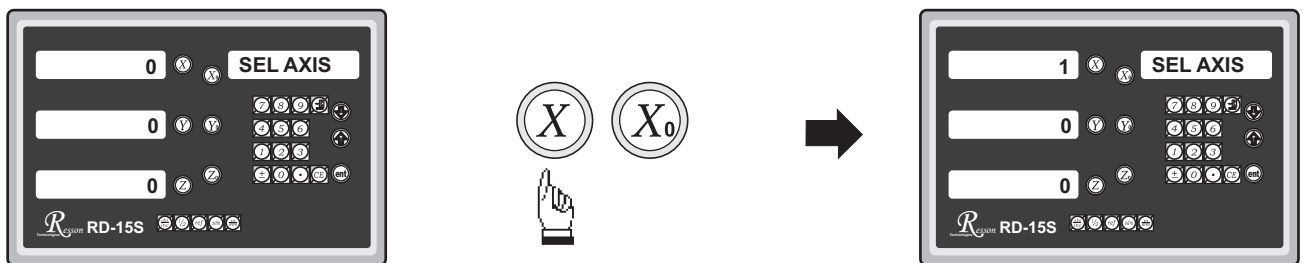

9) Press  to exit; and  or  to “EXIT” and end up the parameter setup.

